

# VOICE LIFT

FREE YOUR VOICE

**Dipl. Ing. Gerrit Carstens**  
Product Manager Installed Sound Europe

**Andreas Schmalfeldt**  
Product Manager Conferencing Europe

## Common issues in large conference rooms and auditoriums.

- Large rooms require the speaker to stress their voice
- Audience fatigue due to inaudible sound
- Passing microphones is inconvenient
- PA speaker can cause feedback



# VOICE LIFT



## What is Voice Lift?

Its **not** Speech reinforcement



# VOICE LIFT

## What is Voice Lift?

Its **not** Speech reinforcement



## What is Voice Lift?

Voice Lift is a **hands-free** technology which amplifies speech from any place in the room.

Voice Lift amplifies the speaker's voice just enough to compensate the distance attenuation.



# VOICE LIFT



## BENEFITS

- No need for handheld, lapel or table microphones
- The speaker can move freely without taking care of any microphone or loudspeakers
- Delivers a comfortable environment for the speaker



## WHERE TO USE

- Conference and board rooms.
- Lecture halls and training centers.
- Government and council chambers.
- Corporate collaboration and hybrid workspaces.
- Educational institutions and auditoriums.



## Design & Planning

Key considerations:

- Room acoustics
- Noise level
- Ceiling layout
- Use Case:
  - Presentation style (one to many)
  - Conference style (many to many)



## Presentation style (one to many)

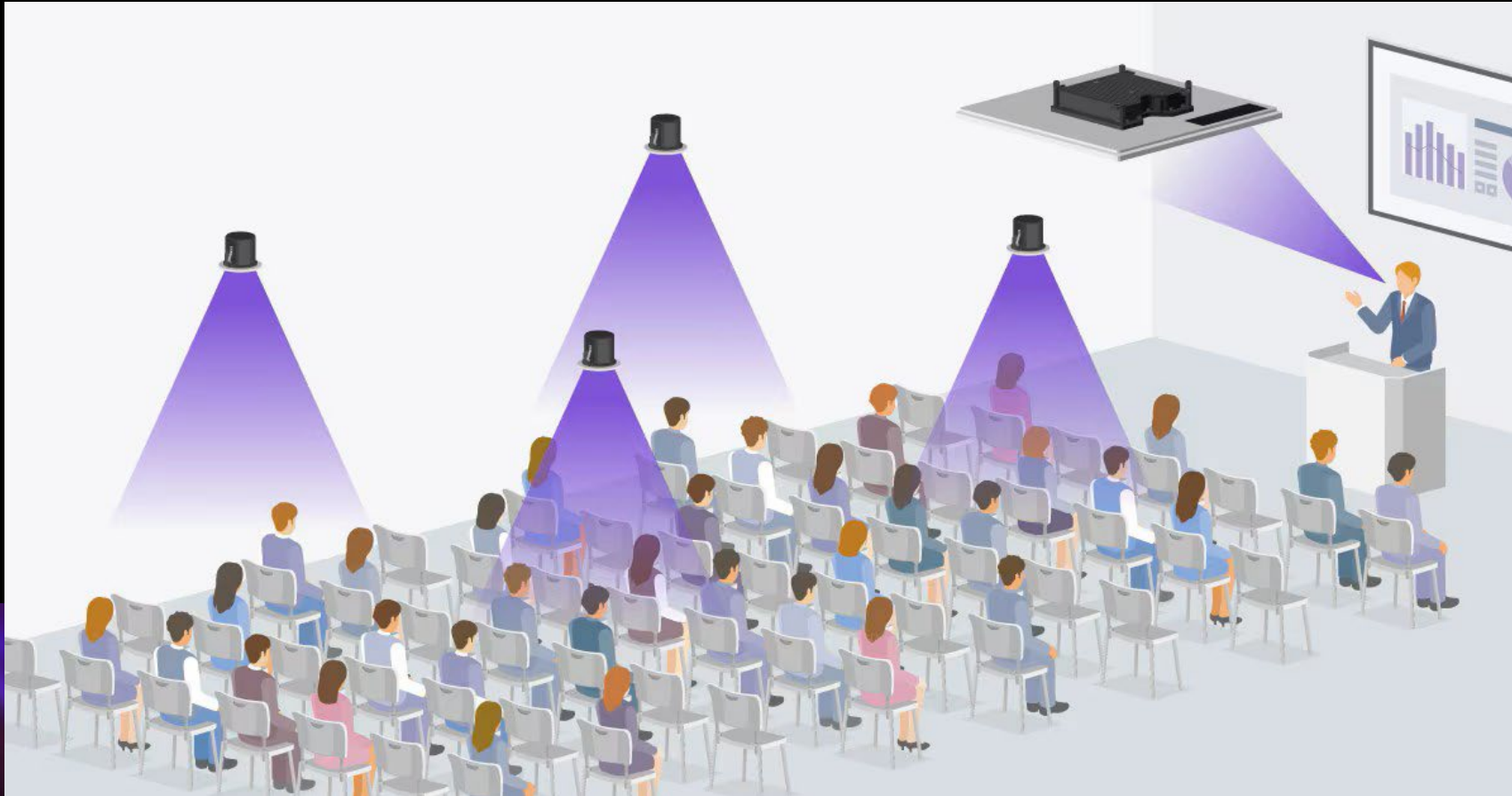

## Conference style (many to many)



## Design & Planning

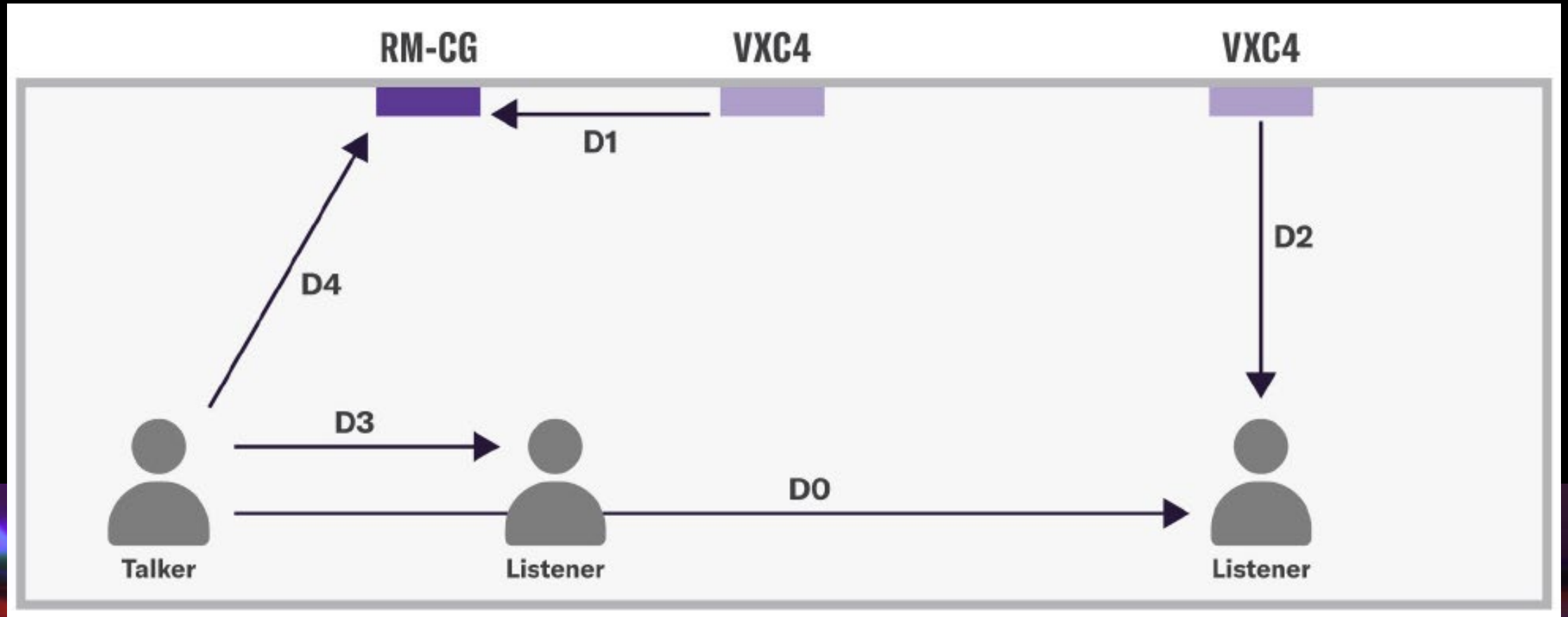

## PAG/NAG Formulas

**PAG:**  $PAG = 20\text{Log}((D0 * D1) / (D2 * D4)) - FSM + CMM$

**NAG:**  $NAG = 20\text{Log}(D0 / D3)$

**0 < PAG and NAG < PAG**

**FSM** Feedback Stability Margin: Estimated fluctuation width of the feedback loop  
(Fixed at 6dB)

**CMM** Ceiling Microphone Margin: Margin for the ceiling microphone  
(Fixed at 10dB)

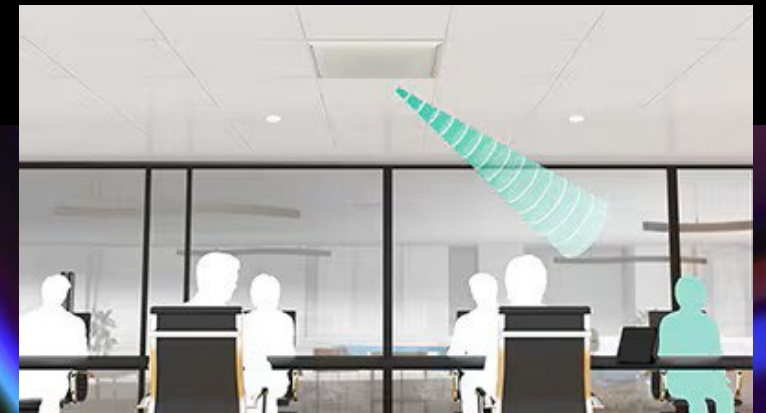

## SYSTEM ARCHITECTURE

- Ceiling microphones (beamforming arrays)
- DSP processor for signal routing and processing
- Amplifiers and ceiling speakers
- Dante audio networking
- Control software for user Control

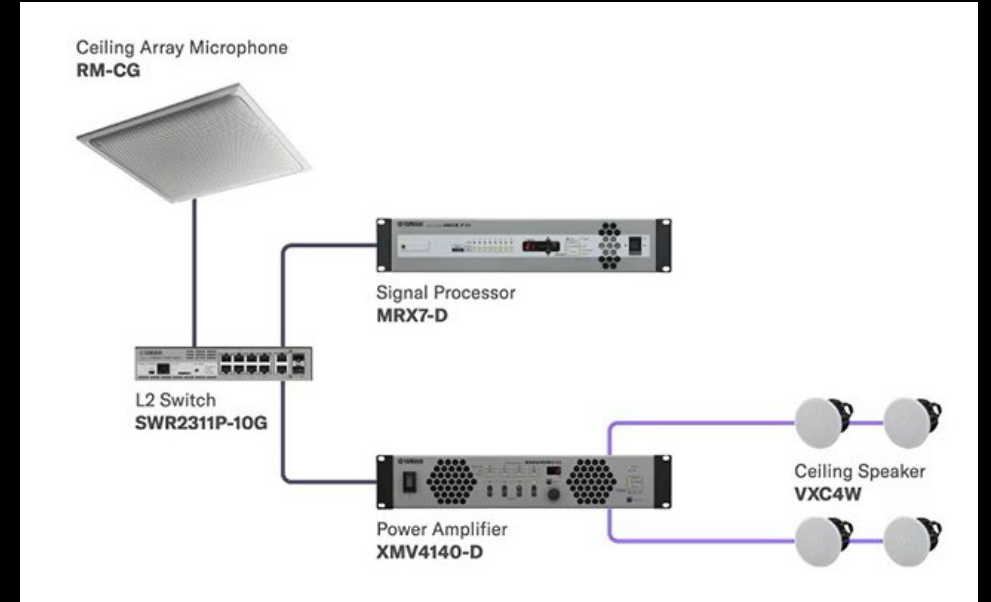

## MICROPHONE TECHNOLOGY

Ceiling array microphones:

- Dynamic beam tracking
- Adjustable tracking areas
- Adaptive beamforming for multiple speakers
- Low latency output



## DSP Processing Details

The DSP core handles:

- EQ and level control
- Notch filtering | pitch shifting reduces feedback
- Delay matrix for spatial consistency
- Gate and Ducker
- Automatic microphone mixing
- Automatic gain control (AGC)



## LOUDSPEAKER DESIGN

Ceiling-mounted speakers

- Close to the audience
- Especially useful for conference mode
- Wide dispersion pattern for even coverage
- Narrow dispersion pattern for higher STI



# SYSTEM ARCHITECTURE



## CONTROL PANEL

- Customized control panels allow a clear adjustments within a defined range

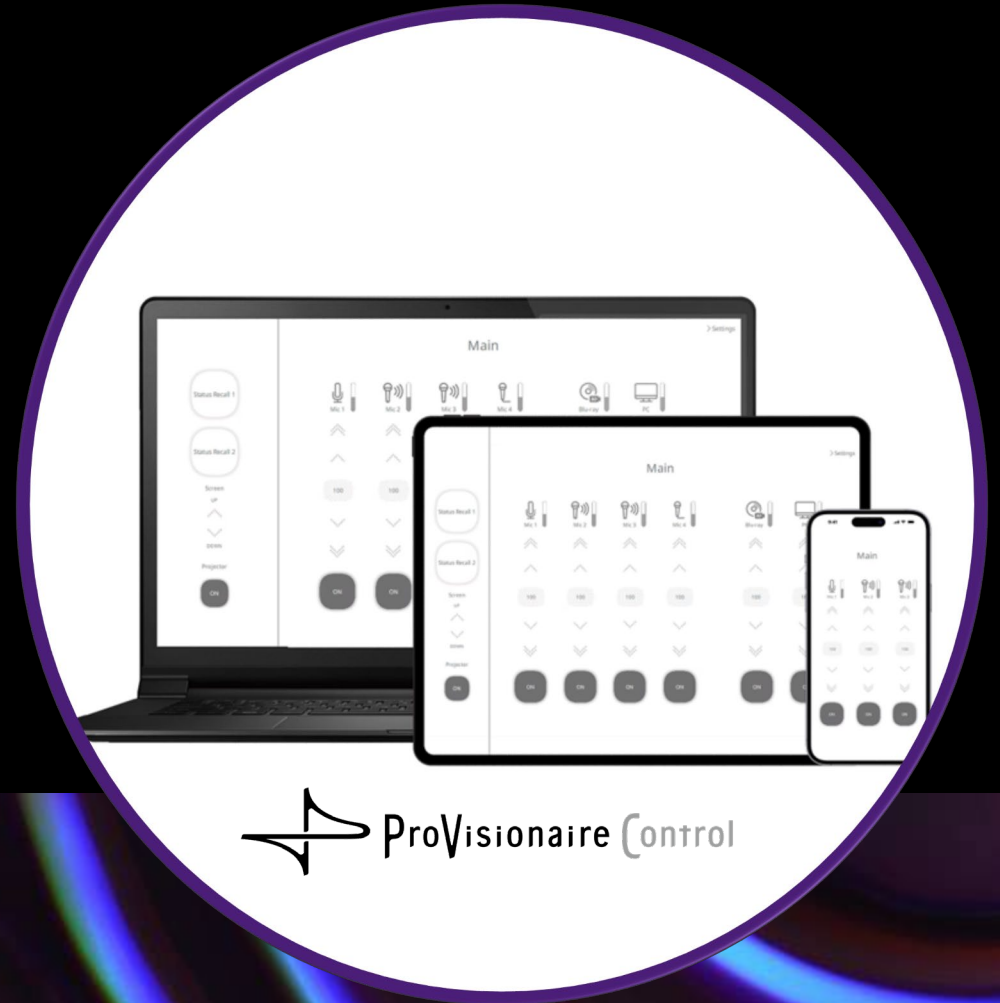

# **SYSTEM EXAMPLE**

## **Wien Museum**

## Installed devices for Voice Lift

6 x Yamaha RM-CG

12 x Yamaha VXC2P

1 x Yamaha DME7



# SYSTEM IMPLEMENTATION



## DSP configuration

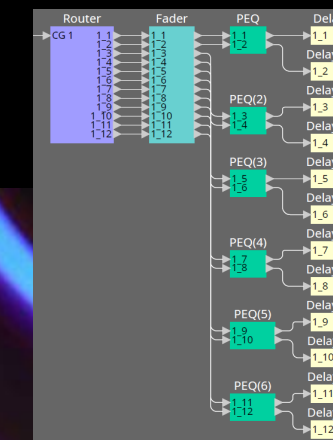
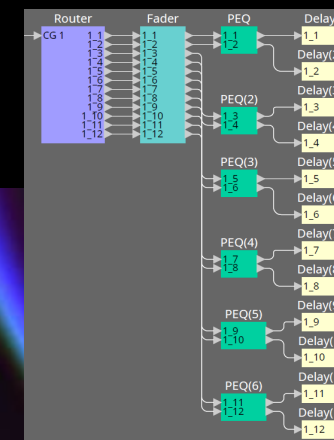
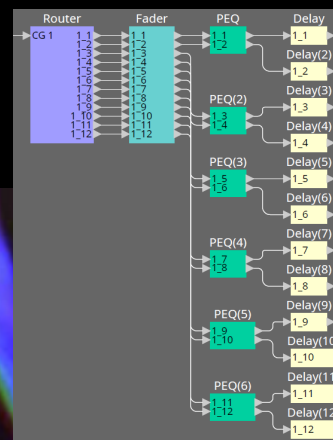
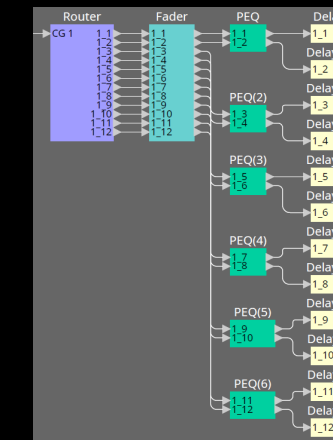
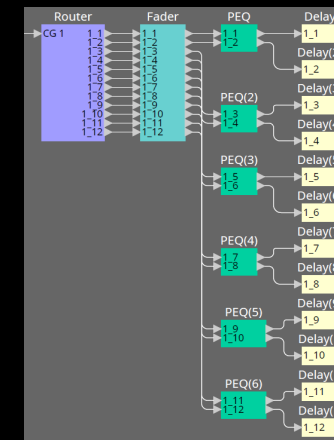
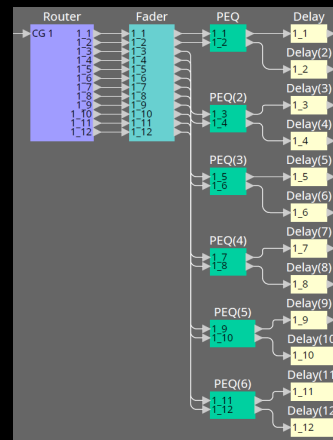
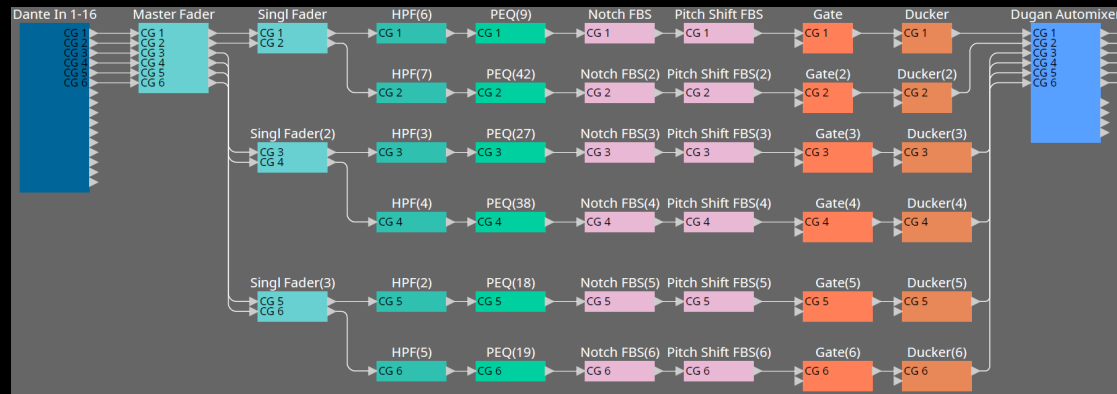

## Tuning procedure

1. Speaker tuning (EQ and level)
2. Microphone settings (tracking areas, automix algorithm)
3. For each Mic and Speaker combination (mics x speakers)
  1. Transfer function measurement
  2. Level delay and EQ setting
4. On every Microphone Bus:
  1. FBS, Gate, Automixer

Estimated Tuning Time is about 2 Days



**Hard to realise a Voice – Lift system?**

# PLANNING EXPERTISE

## DEVICE PLACEMENT

Precise positions must be found, taking into account the device characteristics.

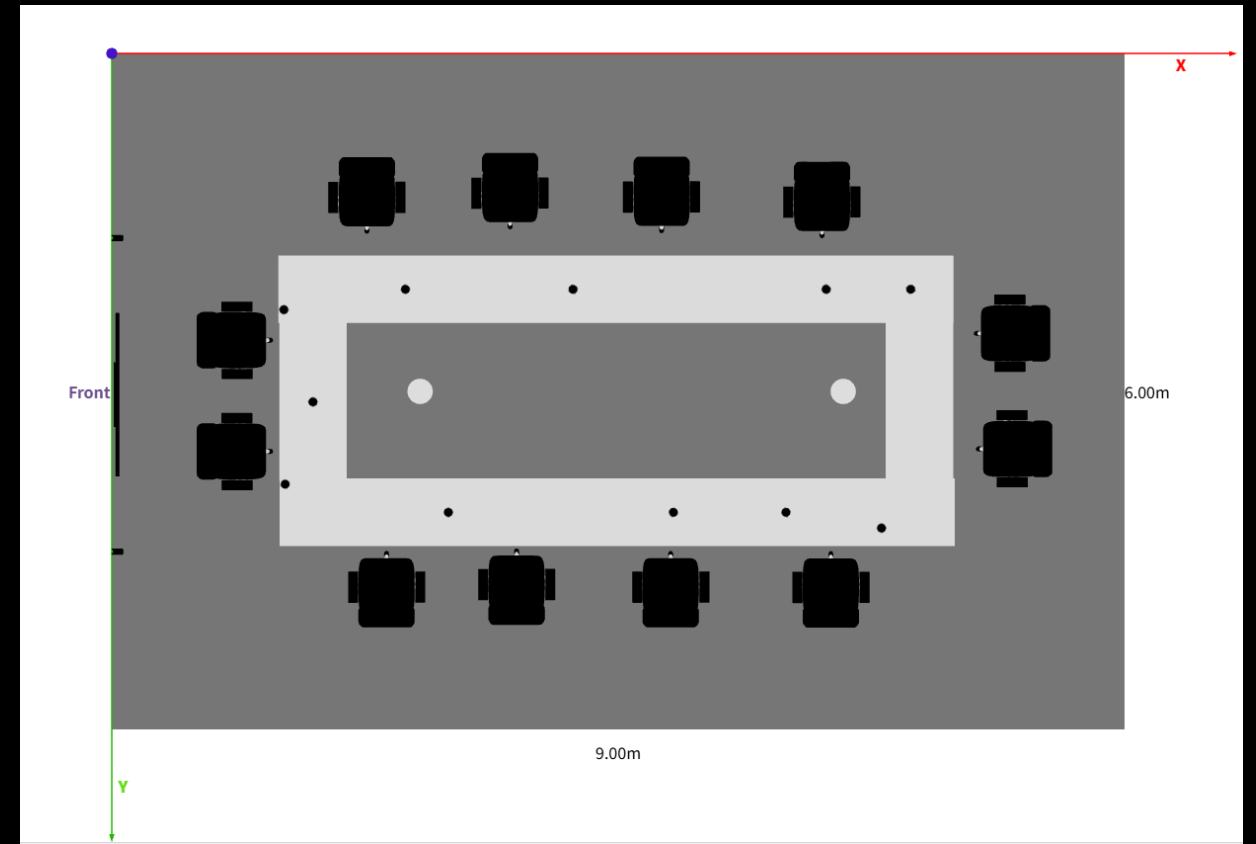

# ACOUSTIC EXPERTISE



## ACOUSTIC SIMULATION

Based on the given positioning, a reliable acoustic calculation must be performed.

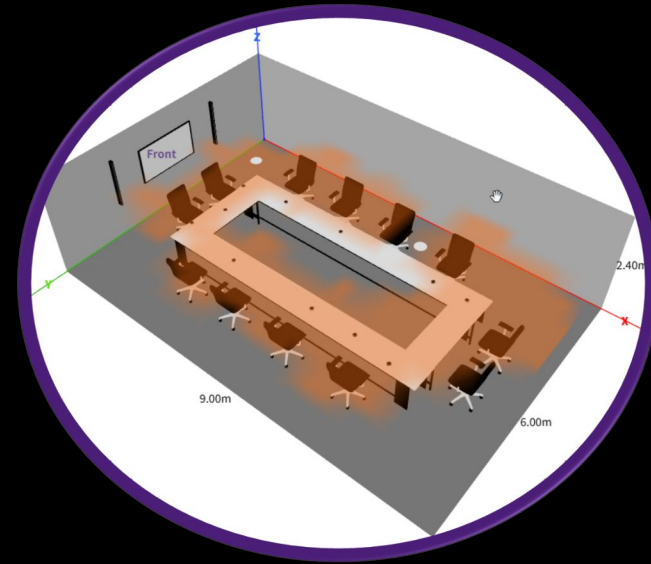

Microphone coverage

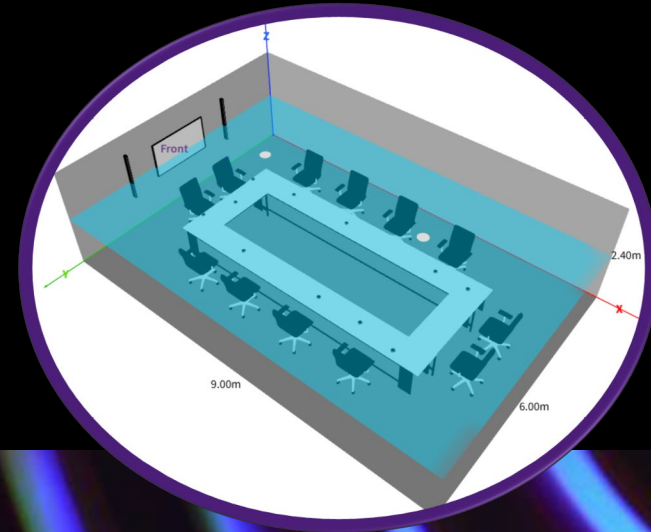

Loudspeaker coverage

## DANTE PATCHING

The signal paths must be precisely aligned with each other.

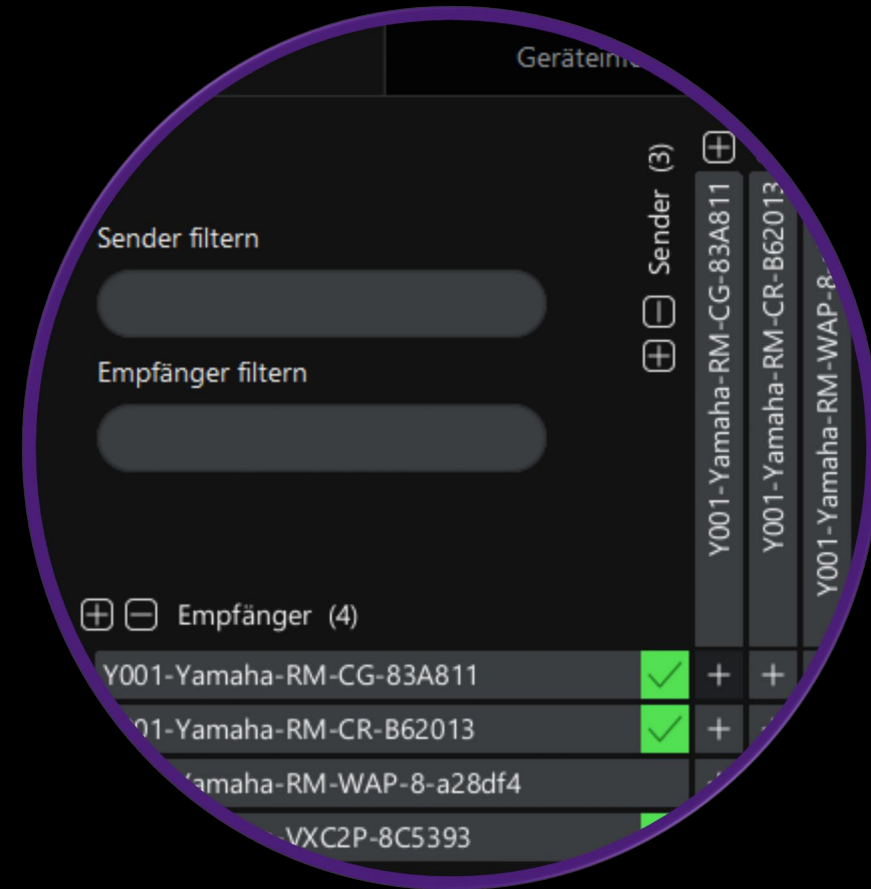

## Audio Tuning

Many parameters now need to be adjusted in the DSP to achieve the optimal voice lift.

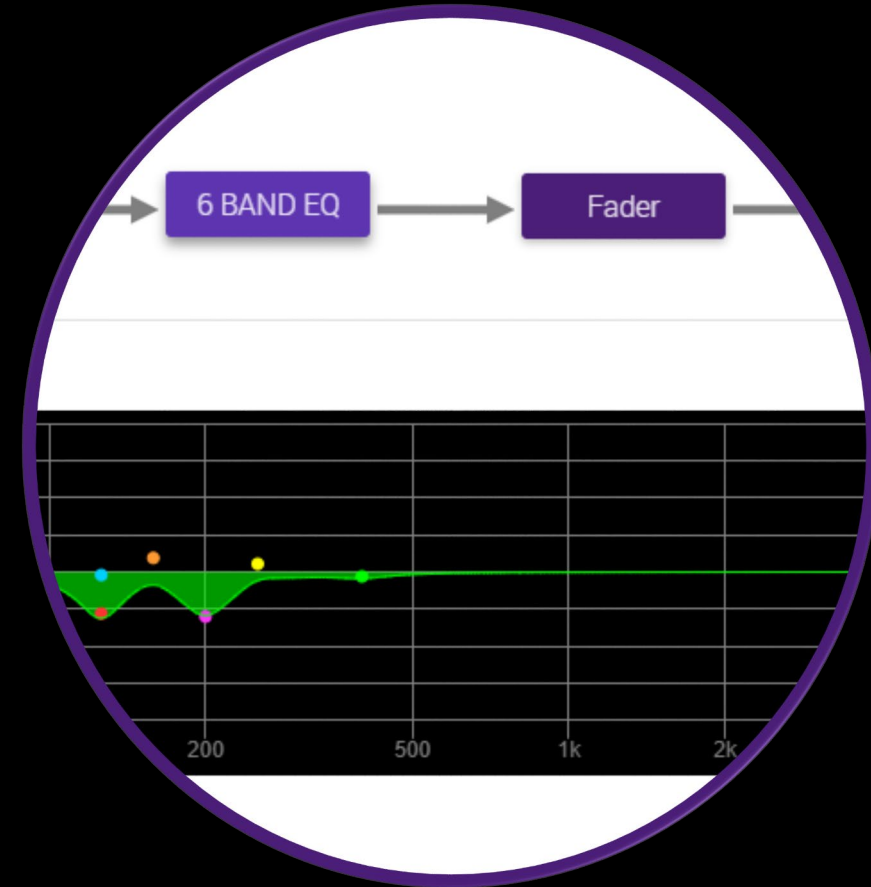

**Isn't there an easier way?**

# VOICE LIFT WITH ADECIA



The new ADECIA 3.0 firmware makes it easy to realise a VoiceLift system.

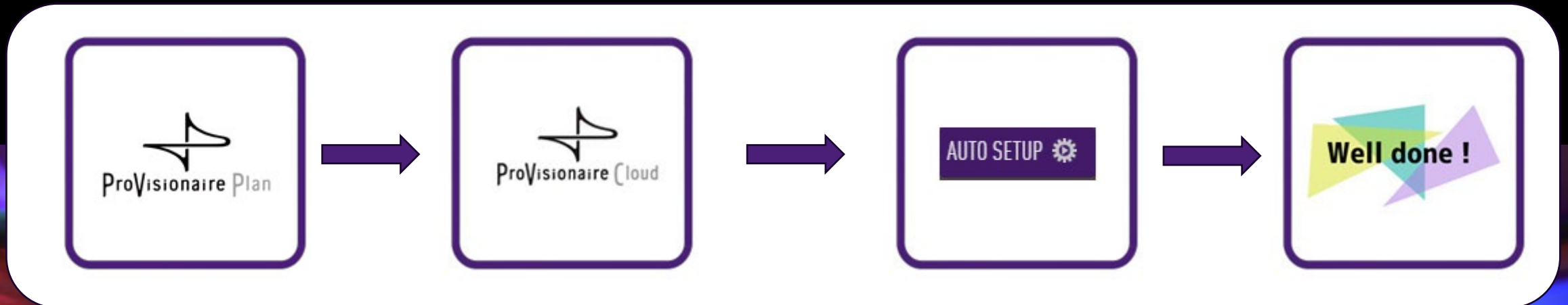

# VOICE LIFT WITH ADECIA



## Step 1: Provisionaire Plan 2.0

Create your room with just a few clicks and let the programme calculate what is needed.

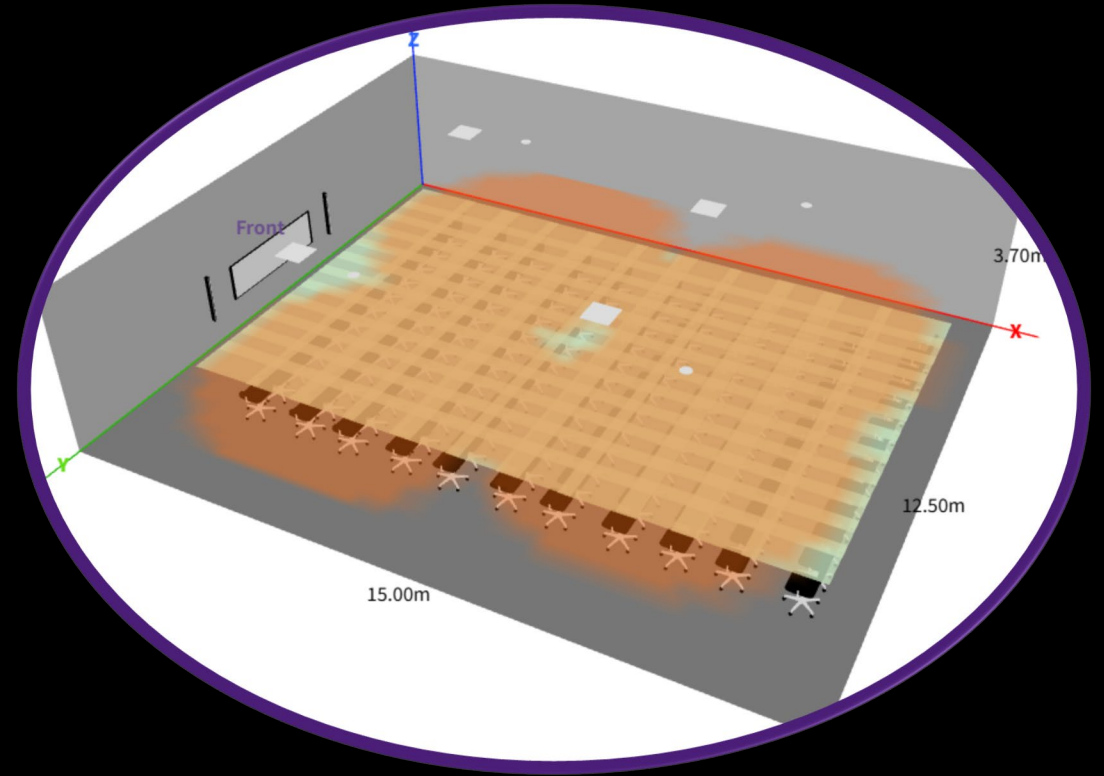

# VOICE LIFT WITH ADECIA



## Step 2: Provisionaire Cloud

Save your Provisionaire Plan result in the Provisionaire Cloud or export the result to your local PC.

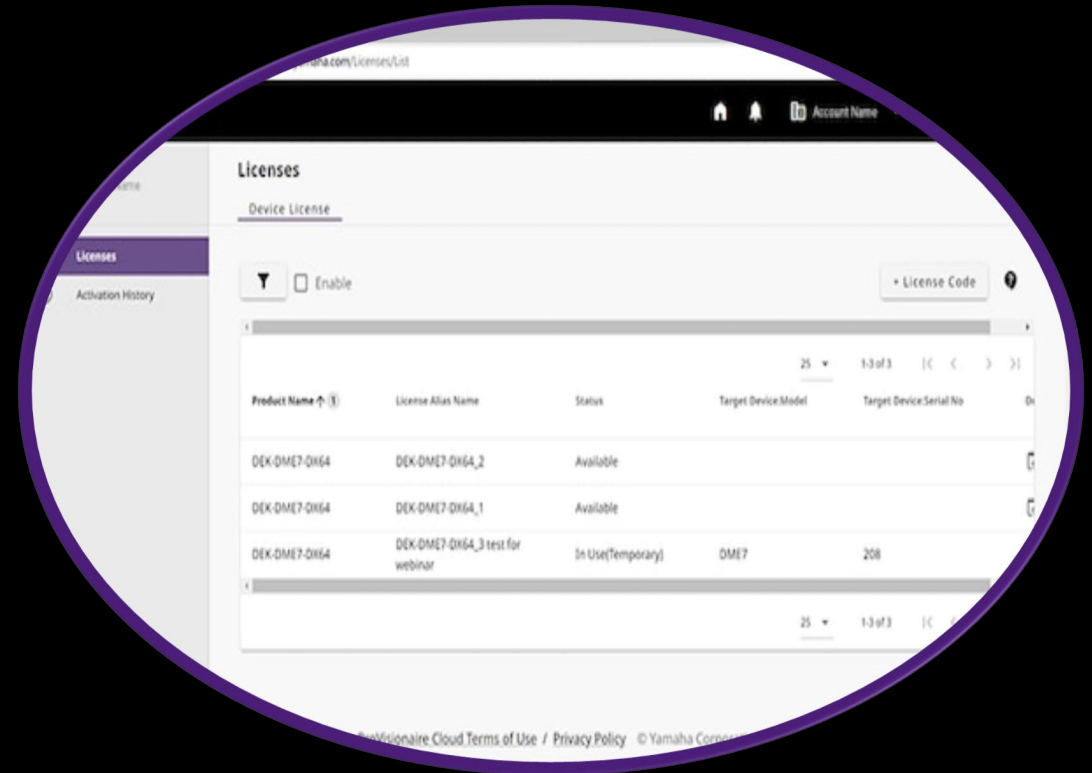

# VOICE LIFT WITH ADECIA



## Step 3: Import the Provisionaire Plan

Now use the plan in RM-CR as the basis for automatic configuration.

...verify, it's essential to set the relative positions of the microphone and speaker correctly.

...the installation location for each registered peripheral device.

...identify button to check the position of each device, then drag and drop it onto the corresponding location number in the list.

...the RM-WAP microphone from the charger and place it at the designated installation location.

...Although VXL1-T6P may be included in the Room Planner data, it will not be listed here, and specifying its location is not required.

The screenshot shows a room plan on the left with dimensions 15.00m and 12.50m. On the right, there is a table with two columns: 'Location' and 'Registered Devices'.

Location	Registered Devices
① RM-CG	Y001-Yamaha-RM-CG
⑪ VXC2P	Y001-Yamaha-RM-CG
	Y001-Yamaha-RM-CG
	Y001-Yamaha-RM-CG
	Y001-Yamaha-RM-CG
	Y001-Yamaha-RM-CG
	Y065-Yamaha-VXC2P-4E6B08
	Y065-Yamaha-VXC2P-4E6B08



# VOICE LIFT WITH ADECIA



## Step 4: Start the Auto Setup

The Auto Setup now handles auto-configuration and automatic audio -tuning.

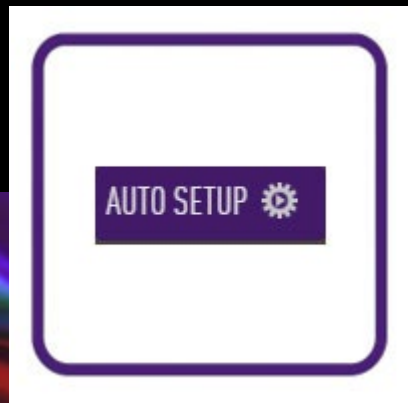

# WIEN MUSEUM



**Installed devices for Voice Lift**

6 x Yamaha RM-CG

12 x Yamaha VXC2P

1 x Yamaha RM-CR

2 x Yamaha SWX2310P-10G



# VOICE LIFT WITH ADECIA



**This room (Wien Museum) requires 2 days for manual tuning.**



**With ADECIA it requires 90 min.**

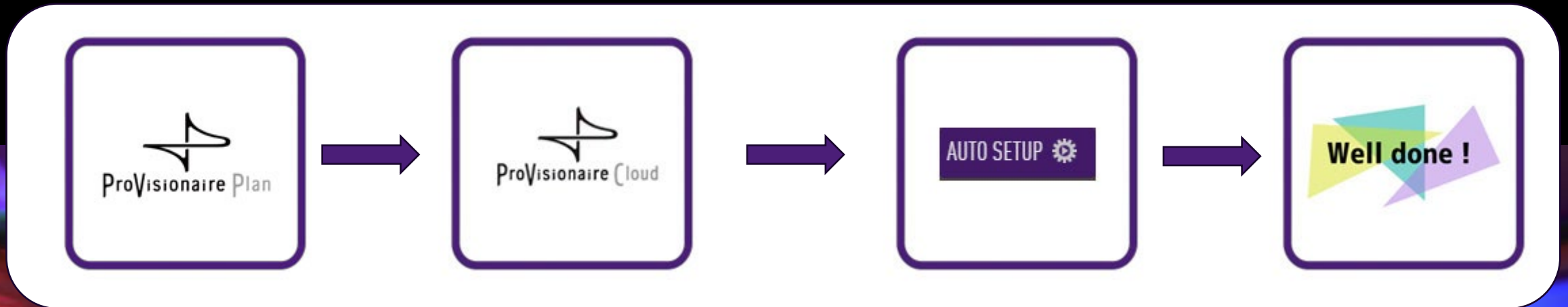

# Q & A



Q: When will ADECIA 3.0 be available?

A: By middle of December you can download the new version

Q: Which microphones are supported for VoiceLift?

A: RM-CG | RM-WAP - > RM-WGS | RM-WGL

Q: Do I need to use Provisionaire Cloud to connect the Provisionaire Plan file to RM-CR?

A: No, it is as well possible to export on local device

Q: Are there any room acoustic requirements for Voice Lift systems?

A: Yes, as lower the reverberation time is, as better the VL results are.



**THANK YOU**

**HAPPY VOICE LIFTING**

