

How Small Can Immersive Be?

Exploring the minimal speaker requirements for truly immersive audio experiences in broadcast environments

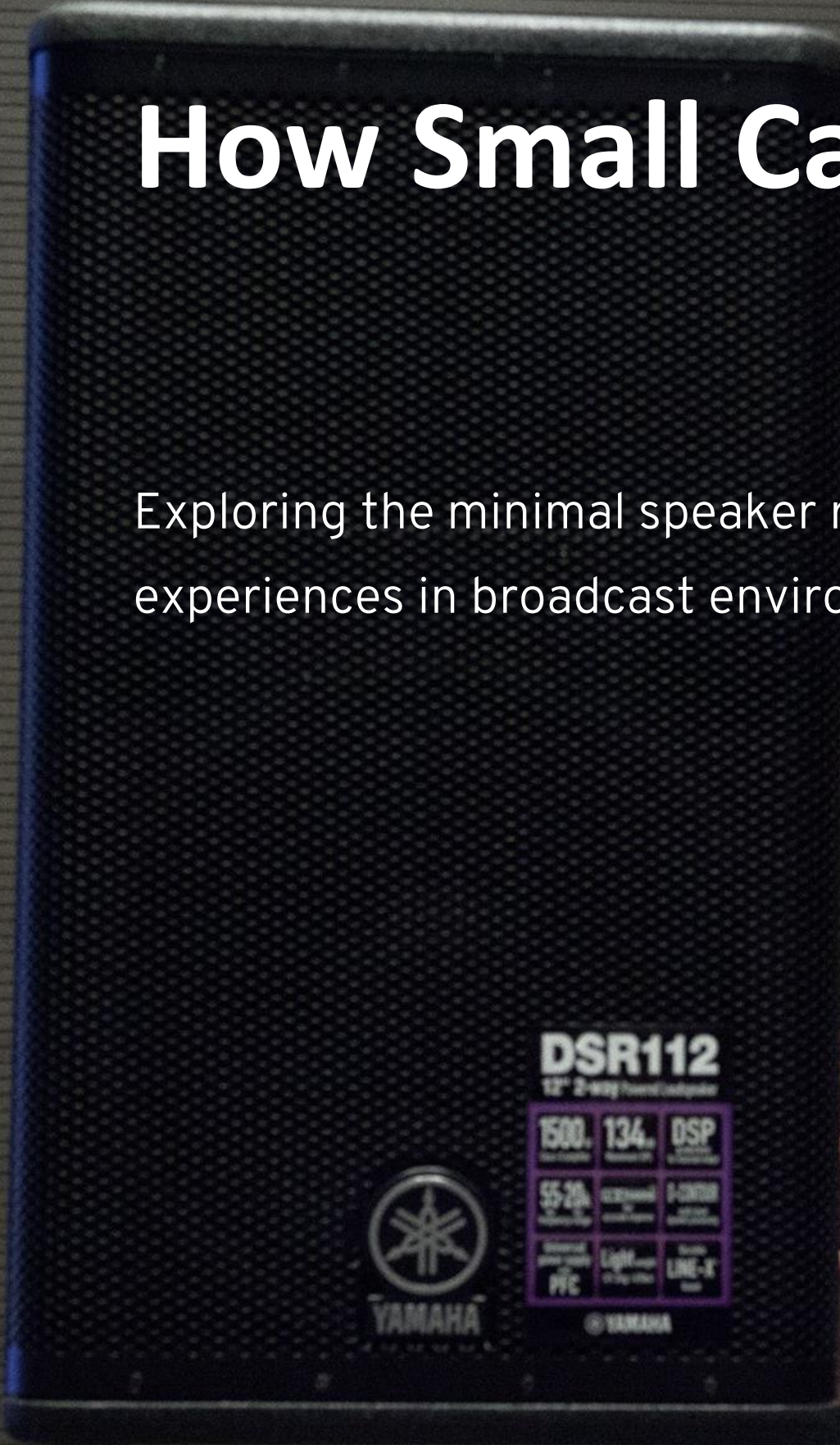

Ing. Wouter "Tony" Verkuijl

Yamaha System Engineering Group

Presented by:



Ing. Gerrit Carstens



Ing. Maciej Błachnio



The Challenge of Immersive Audio

- Traditional 5.1 systems provide spatial audio but lack true immersion.
- Advanced formats like 22.2 offer exceptional quality but require complex installations with dozens of speakers.

The question emerges: What's the minimum configuration that still delivers genuine immersive perception?

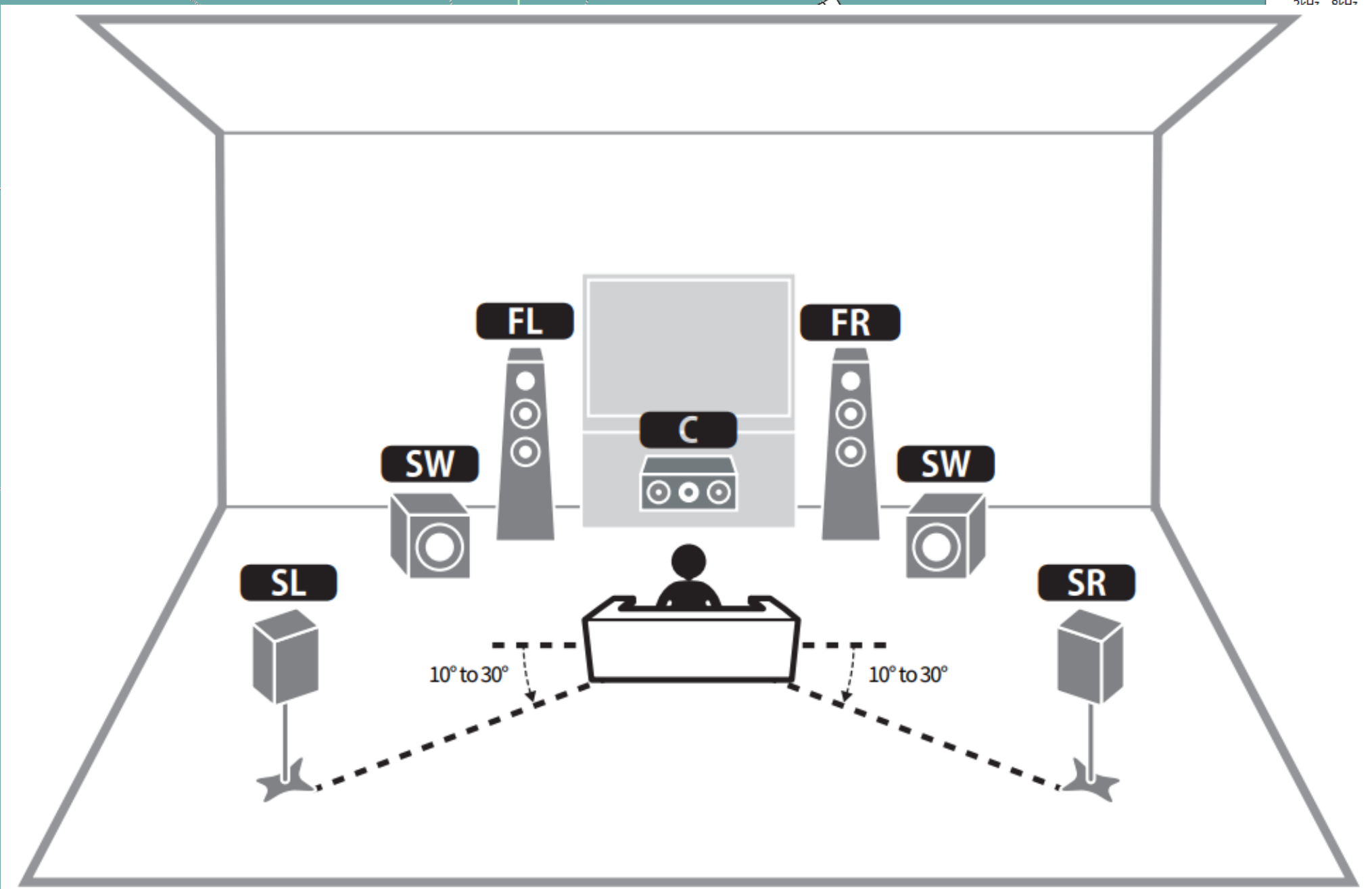
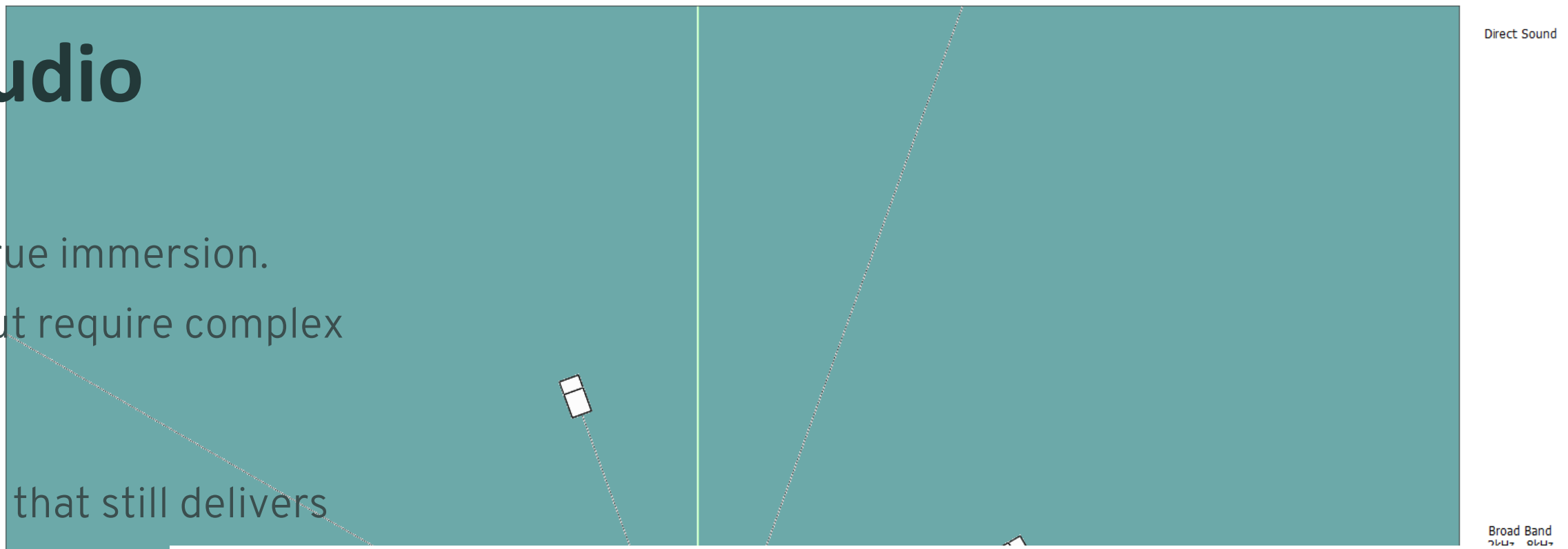
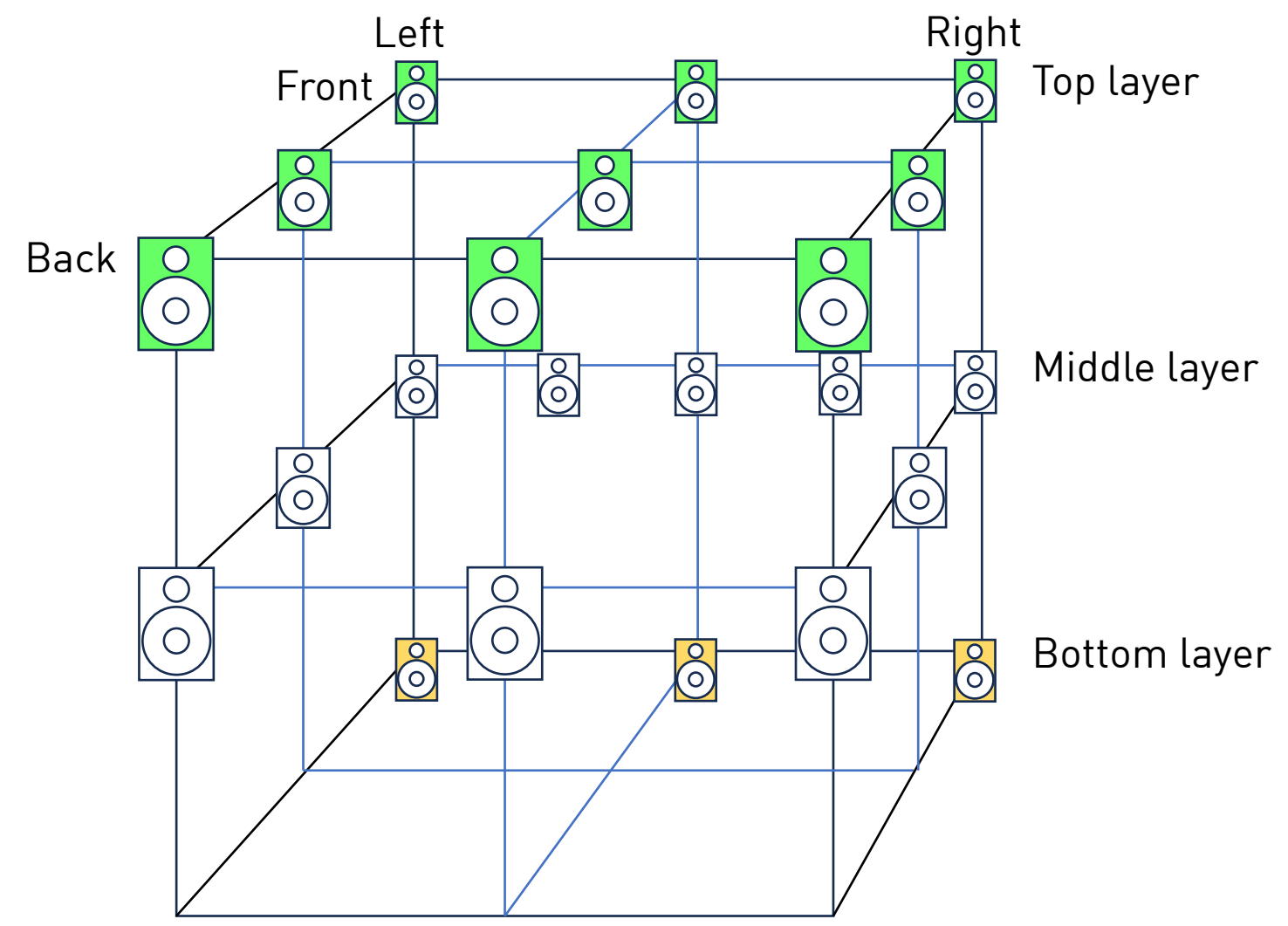

Defining Listener Envelopment (LEV)

LEV Definition

The listener's impression of being in a spatial sound field, feeling completely and uniformly surrounded by sounds from unlocalisable sources

Key Requirements

Spatial homogeneity, sounds coming evenly from all directions that are spatially connected

Measure

Listening panel testing, setting our benchmark for "immersive enough".

Threshold

Scores above 3.5 indicate strong envelopment

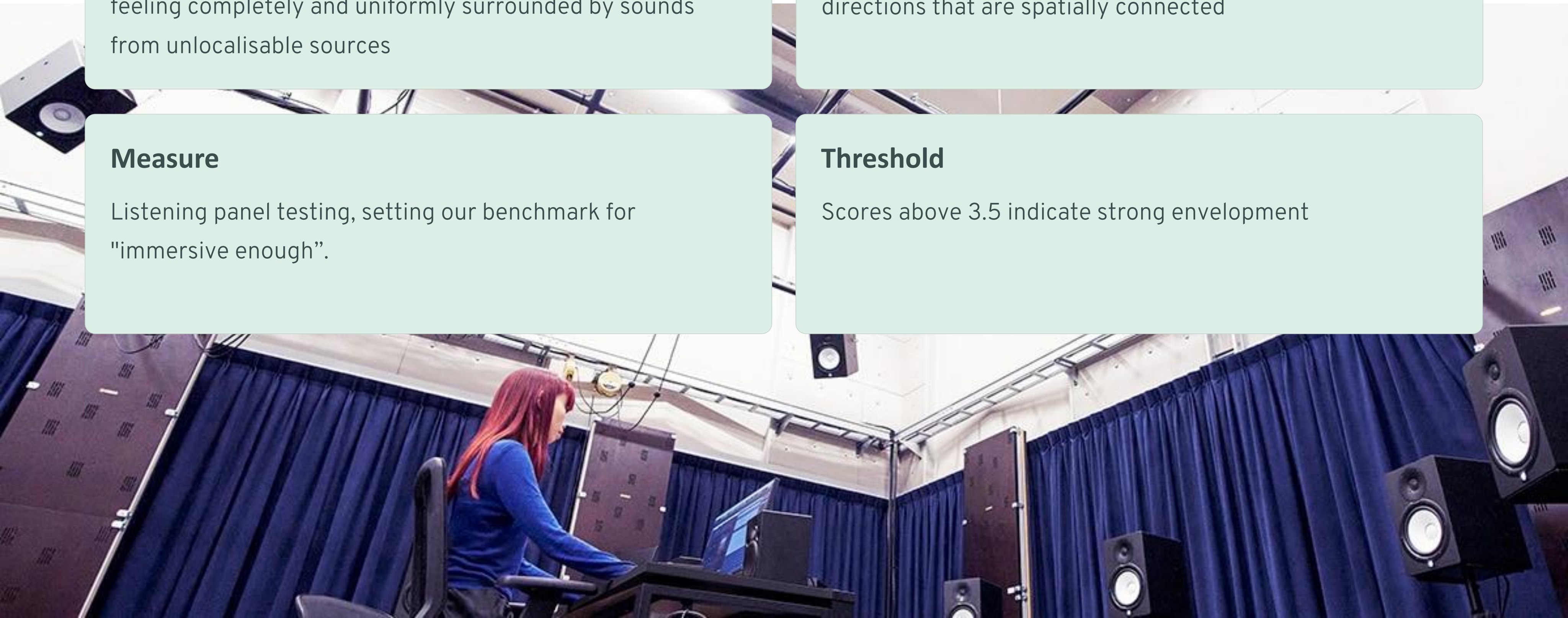

The ITU-R Research

- Extensive studies pinpoint minimum speaker needs for immersion.
- Testing used uncorrelated white noise in controlled settings to measure envelopment.

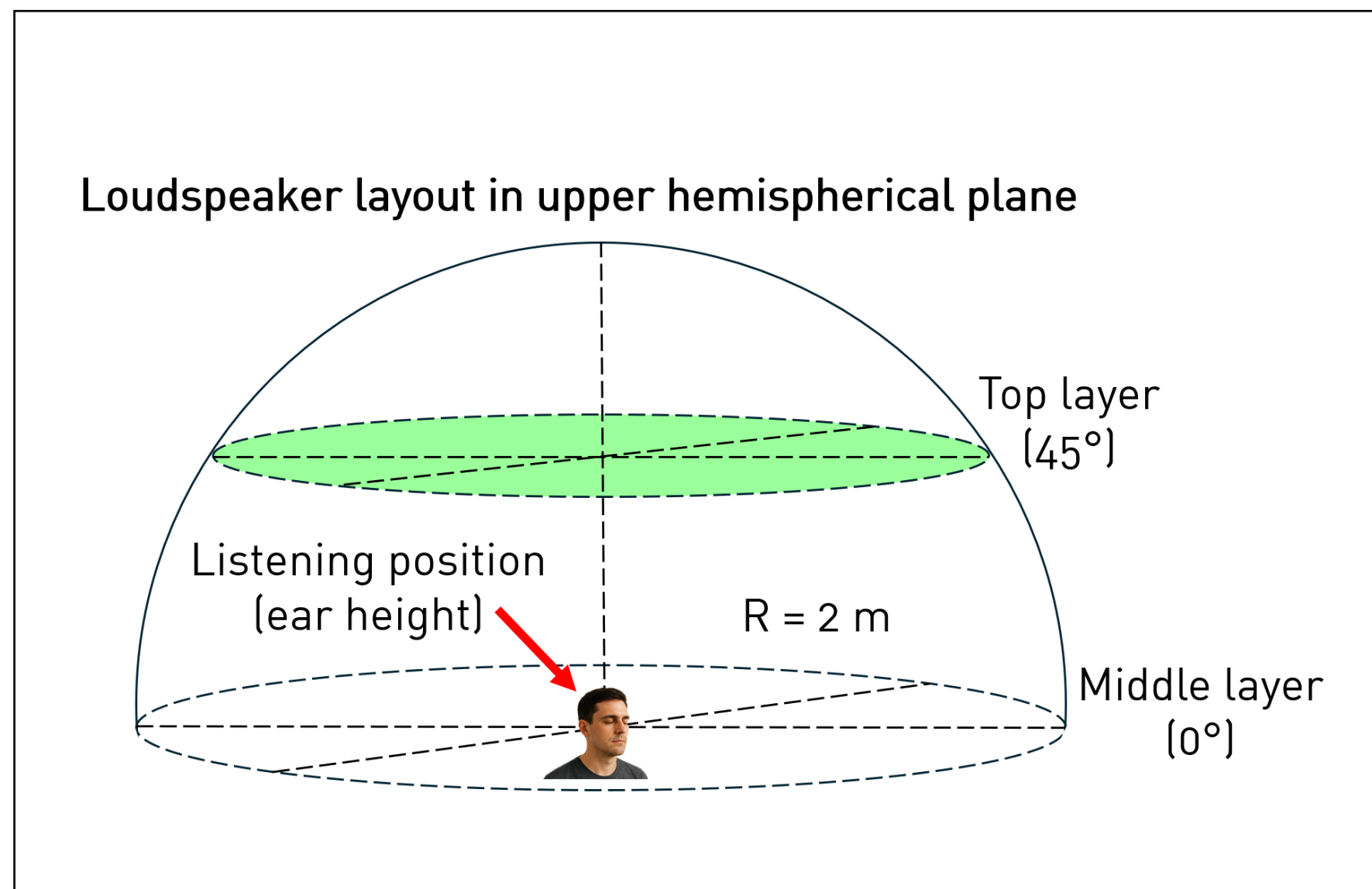

Key Finding: Dual-layer setups (middle + top) enhance LEV by 20-30% over single-layer, even at low channel counts

How Immersion is Tested

Method

20-40 listeners rate a 5-point scale (1="Not at all" to 5="Very much") on envelopment and uniformity.

Stimuli

Uncorrelated white noise bursts; panned for phantom sources.

Thresholds

LEV >3.0 for slight envelopment; >4.0 for a fully immersive feel, achievable with 8-12 channels in dual-layer.

Off-Center Testing

Tested across wide listening areas for real-world relevance

The ITU-R Research: Number of speakers

“ 5.1”

5 loudspeakers

30° - 110°

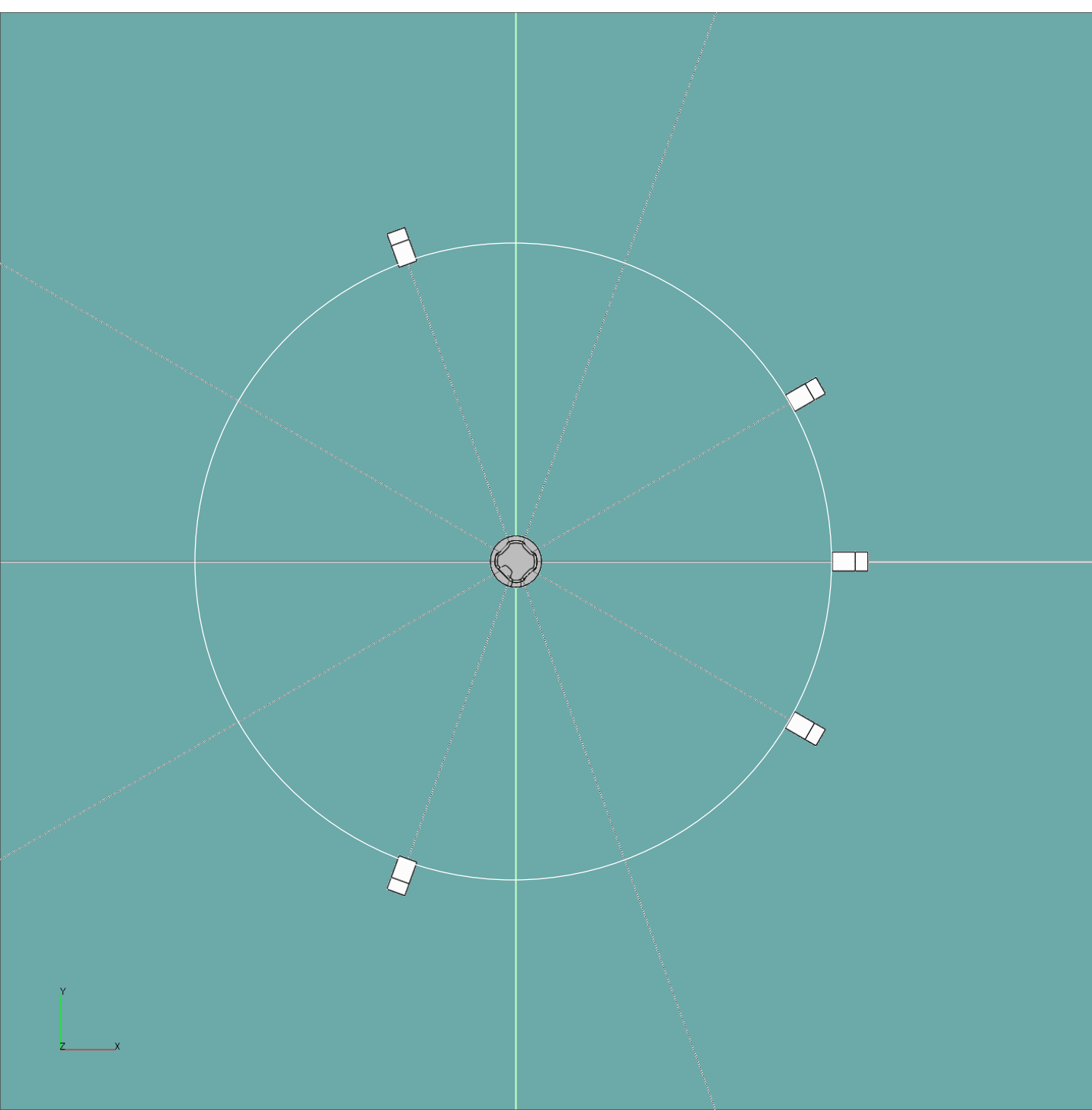

Direct Sound

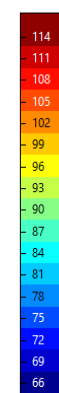

Broad Band
2kHz...8kHz
MIF, Pink
Noise
Headroom =
0

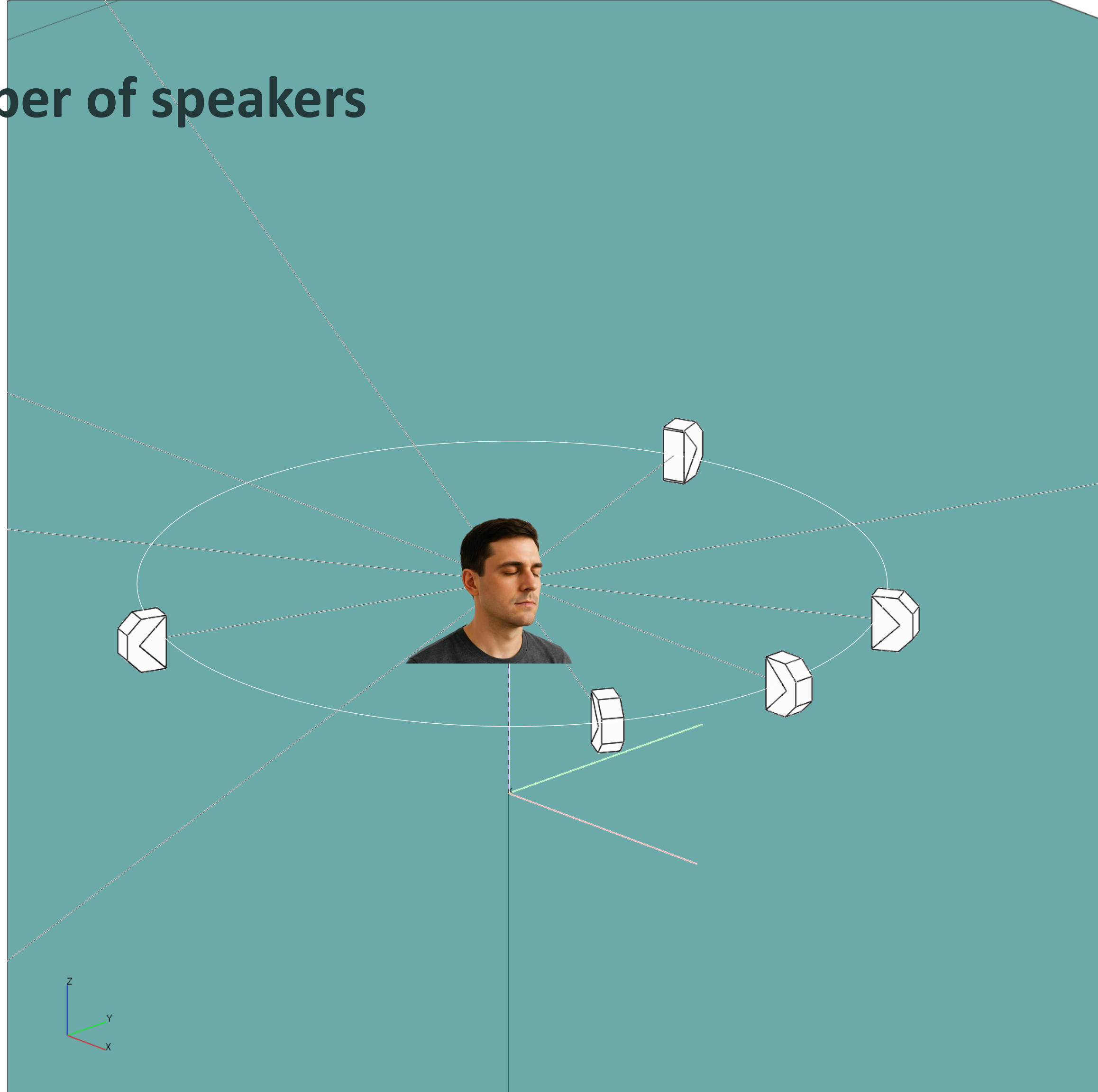

Direct Sound

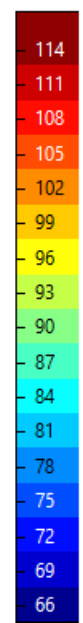

Broad Band
2kHz...8kHz
MIF, Pink
Noise
Headroom =
0

The ITU-R Research: Number of speakers

“ 22.2”

22 loudspeakers

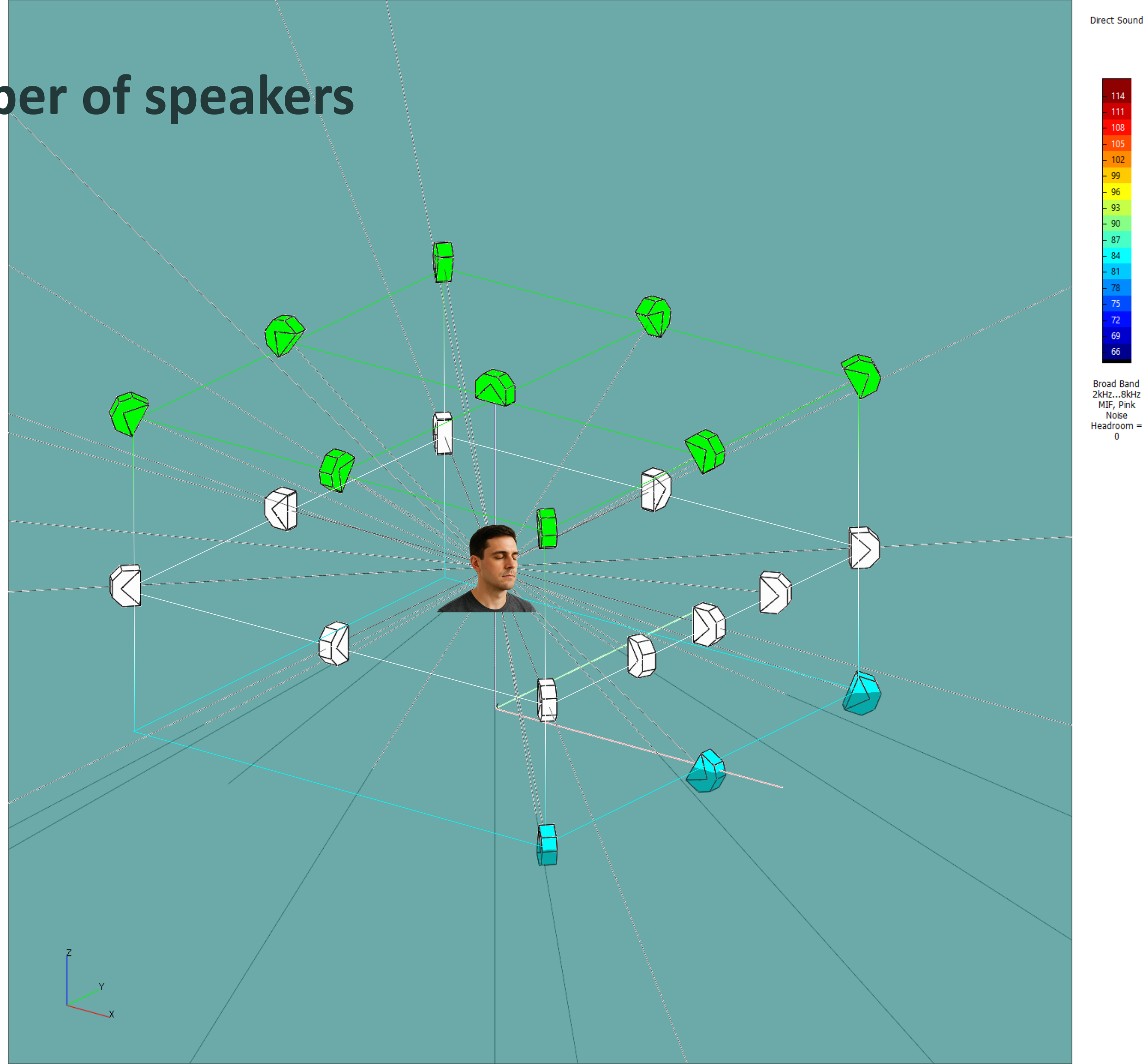
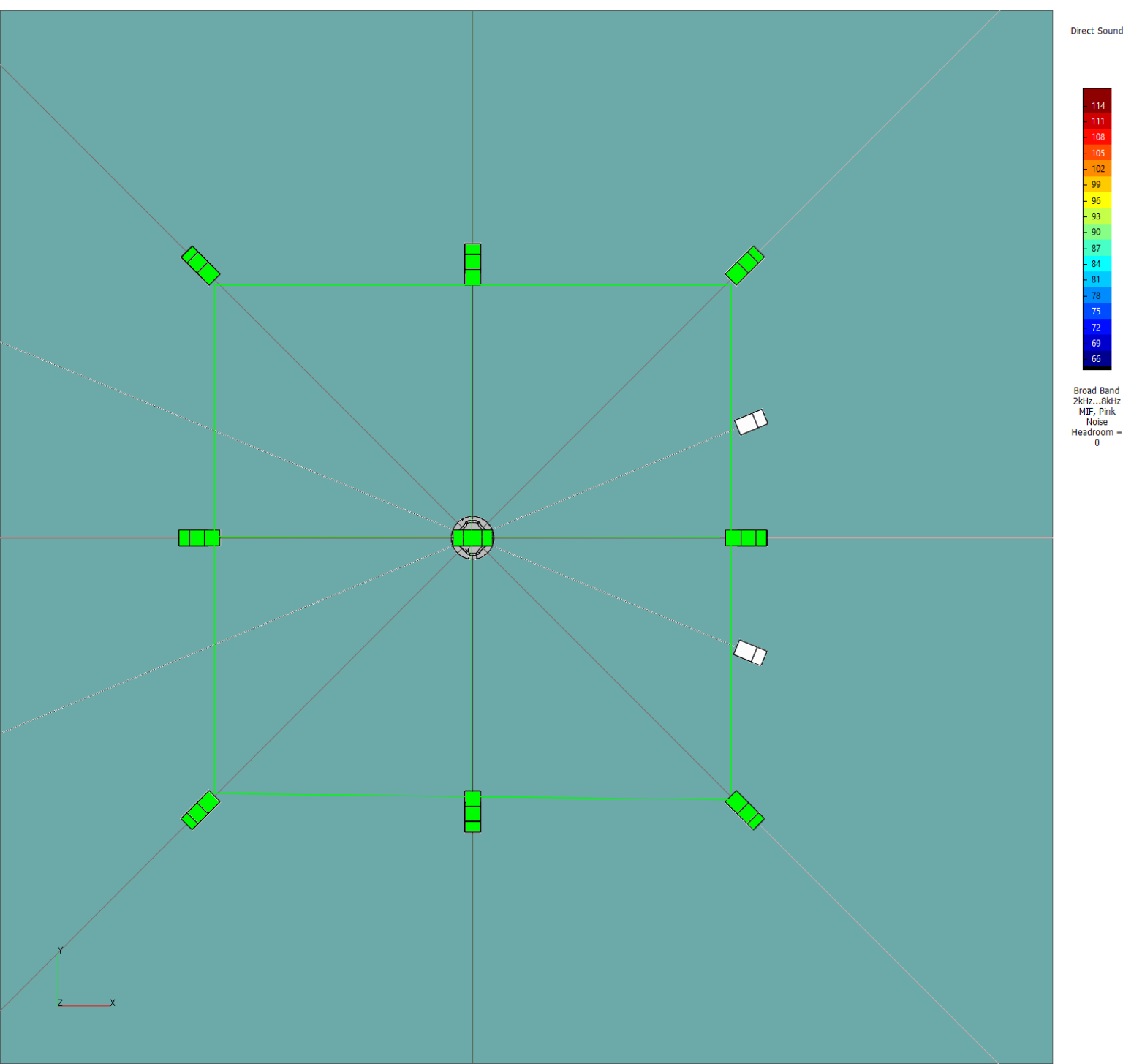

The ITU-R Research: Number of speakers

4 loudspeakers

90° aperture

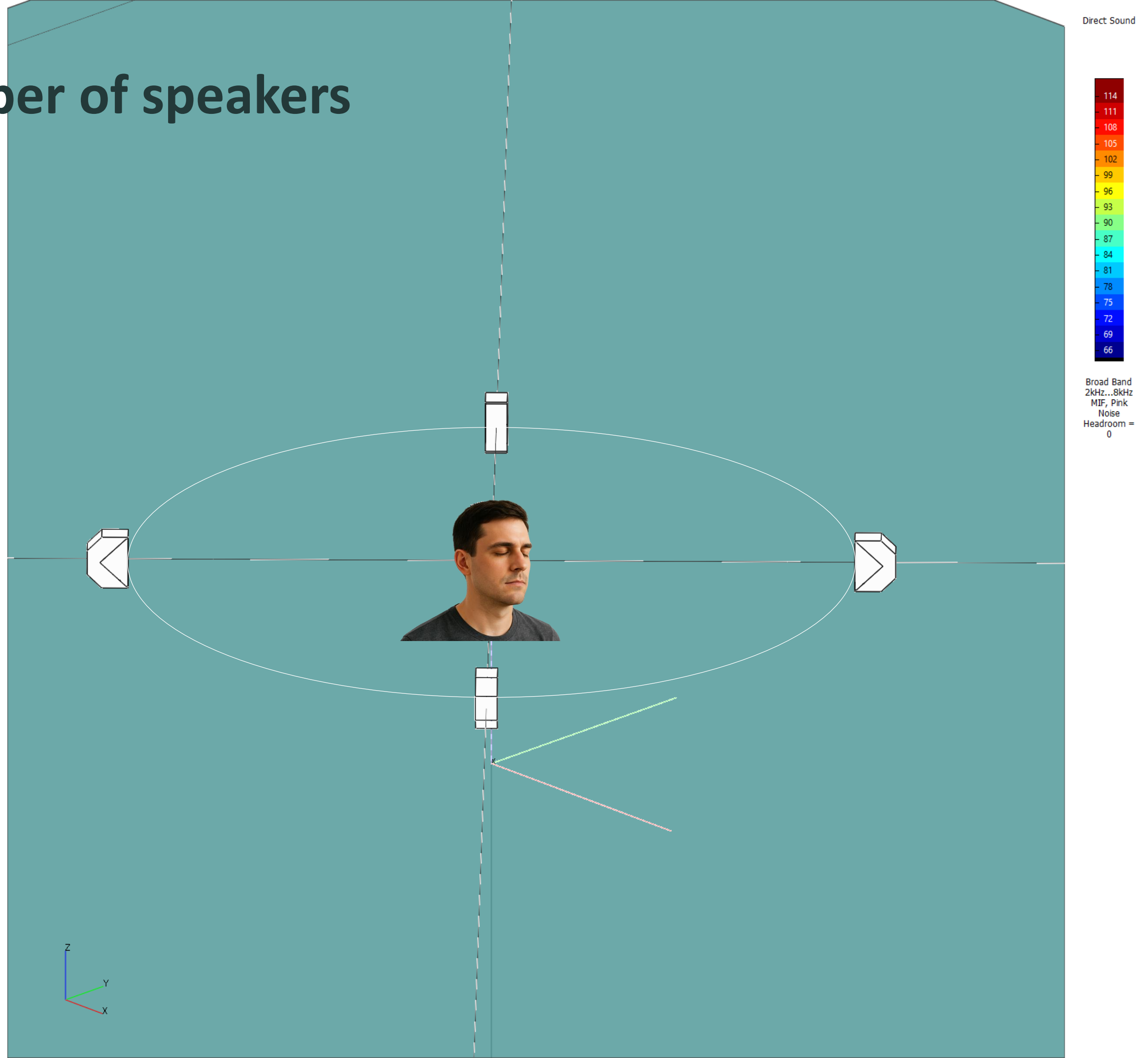
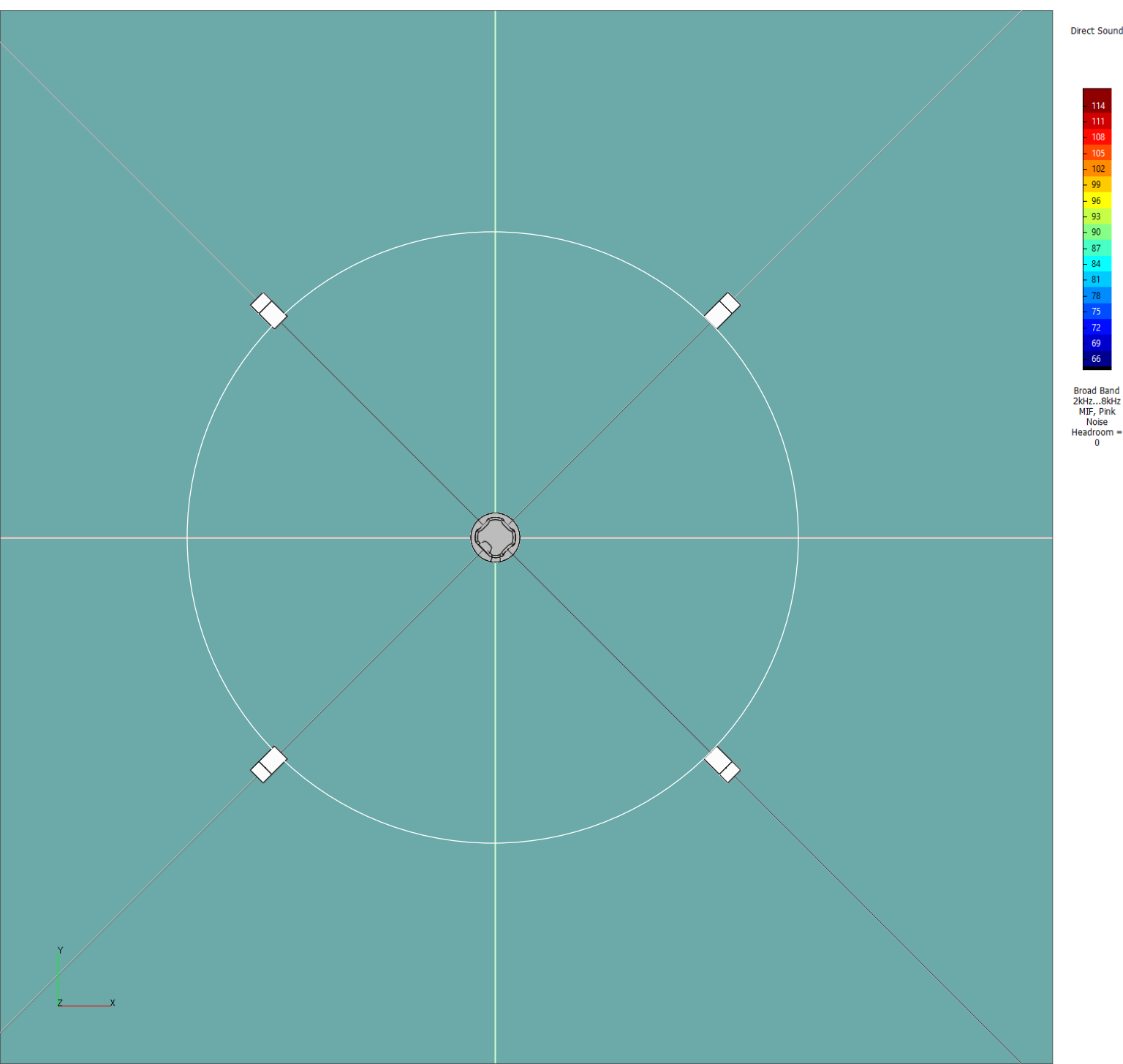

The ITU-R Research: Number of speakers

6 loudspeakers
60° aperture

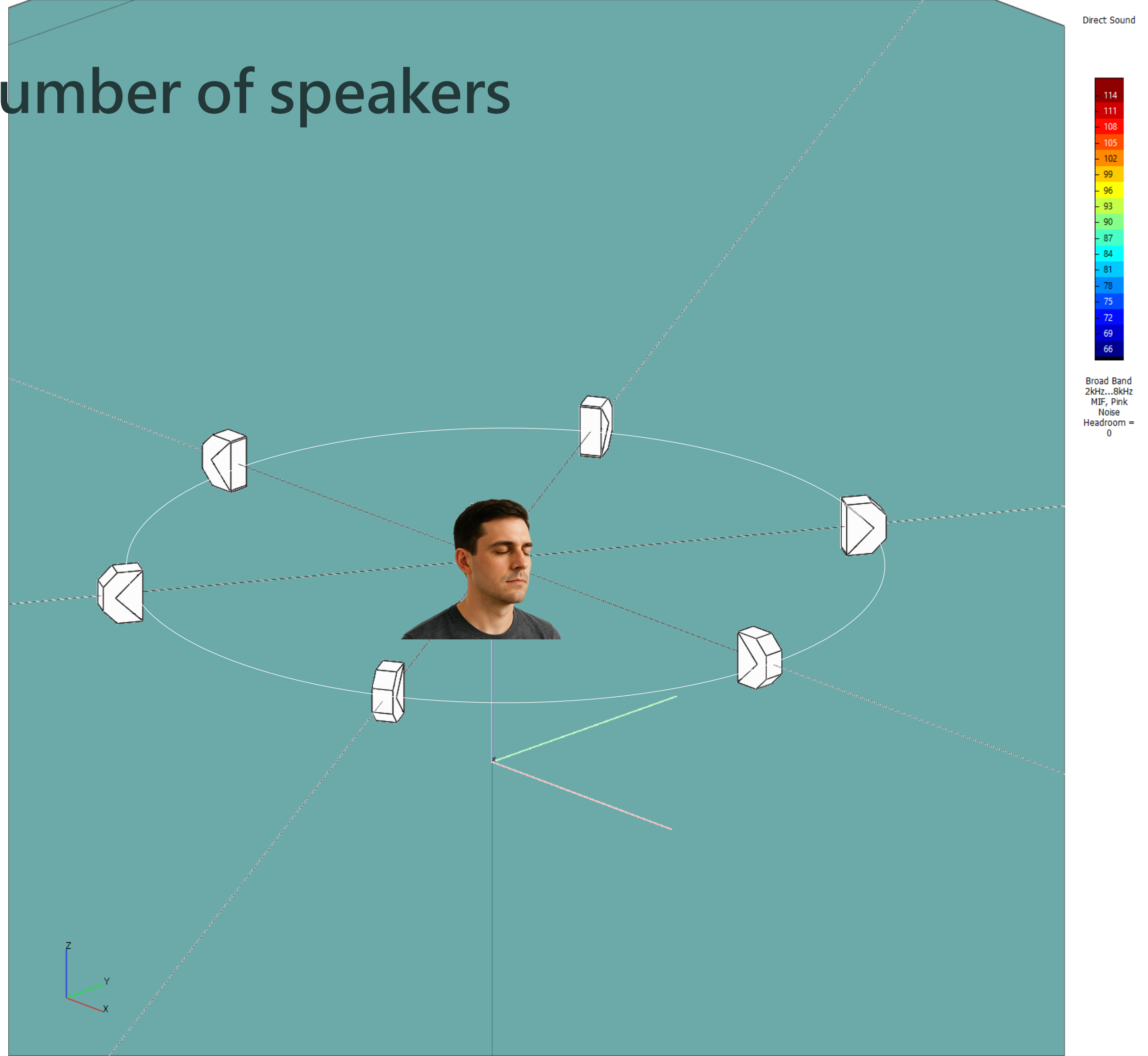
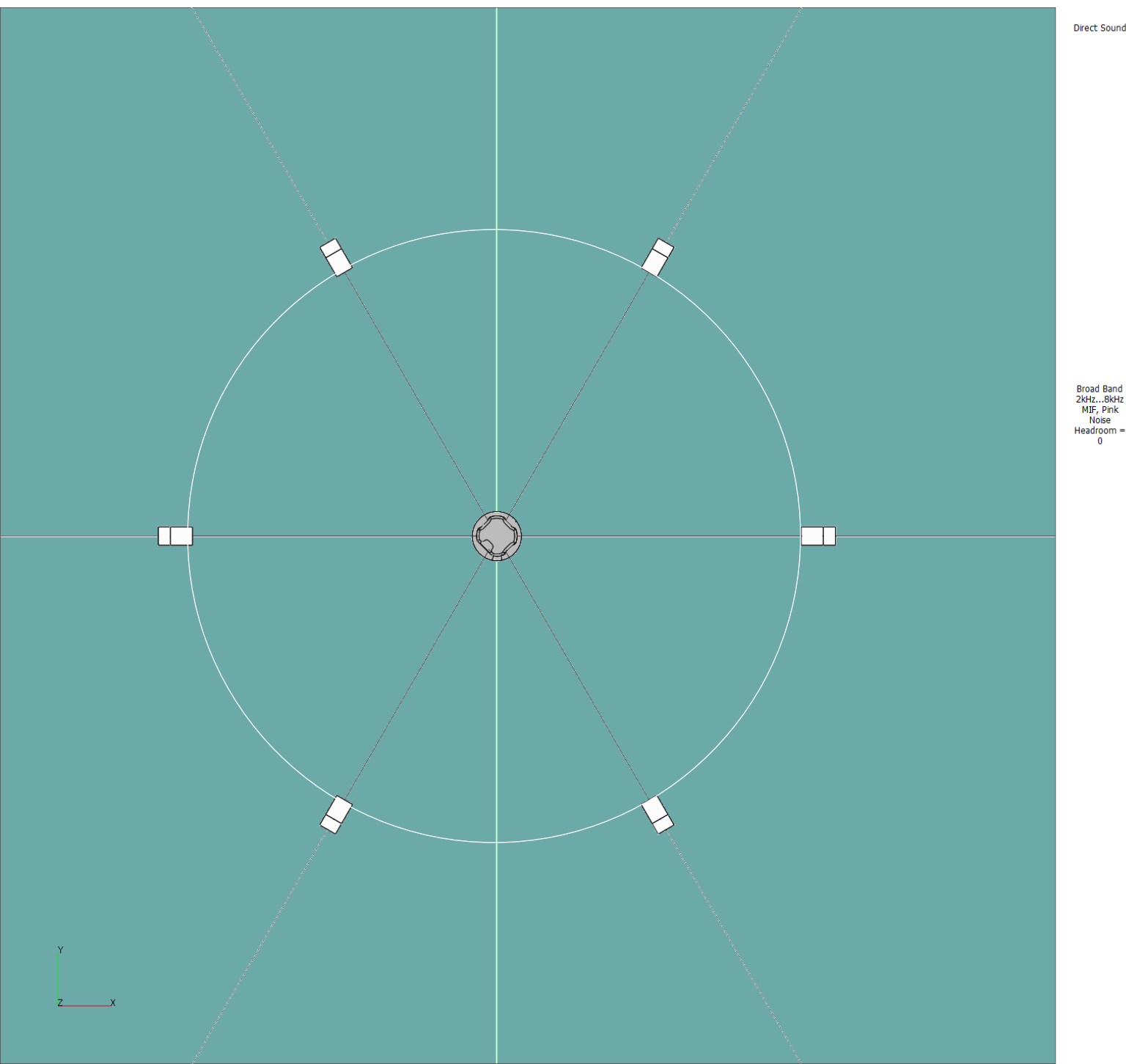

The ITU-R Research: Number of speakers

8 loudspeakers
45° aperture

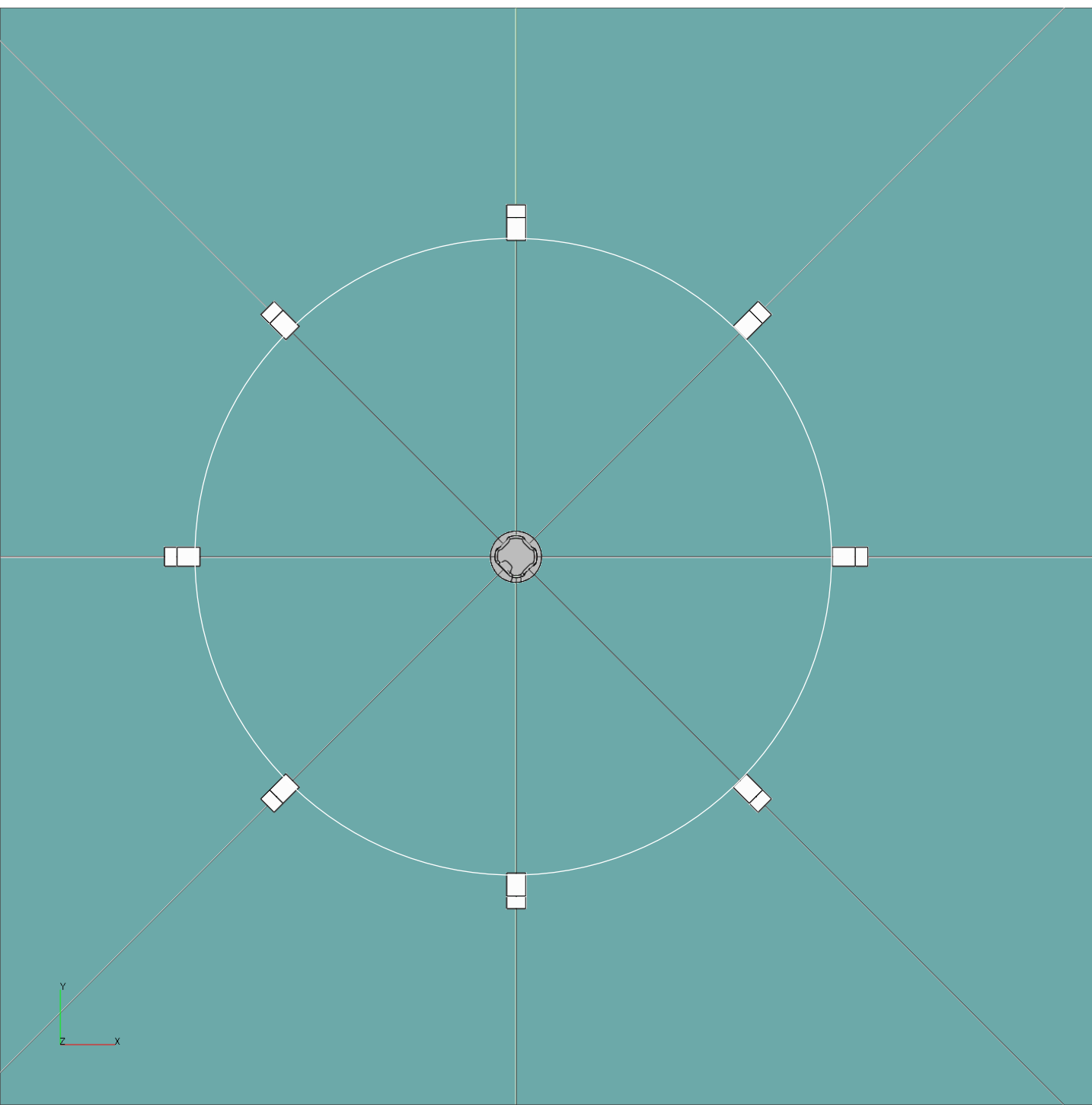

Direct Sound

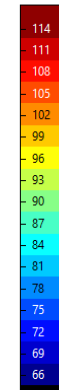

Broad Band
2kHz...8kHz
MIF, Pink
Noise
Headroom =
0

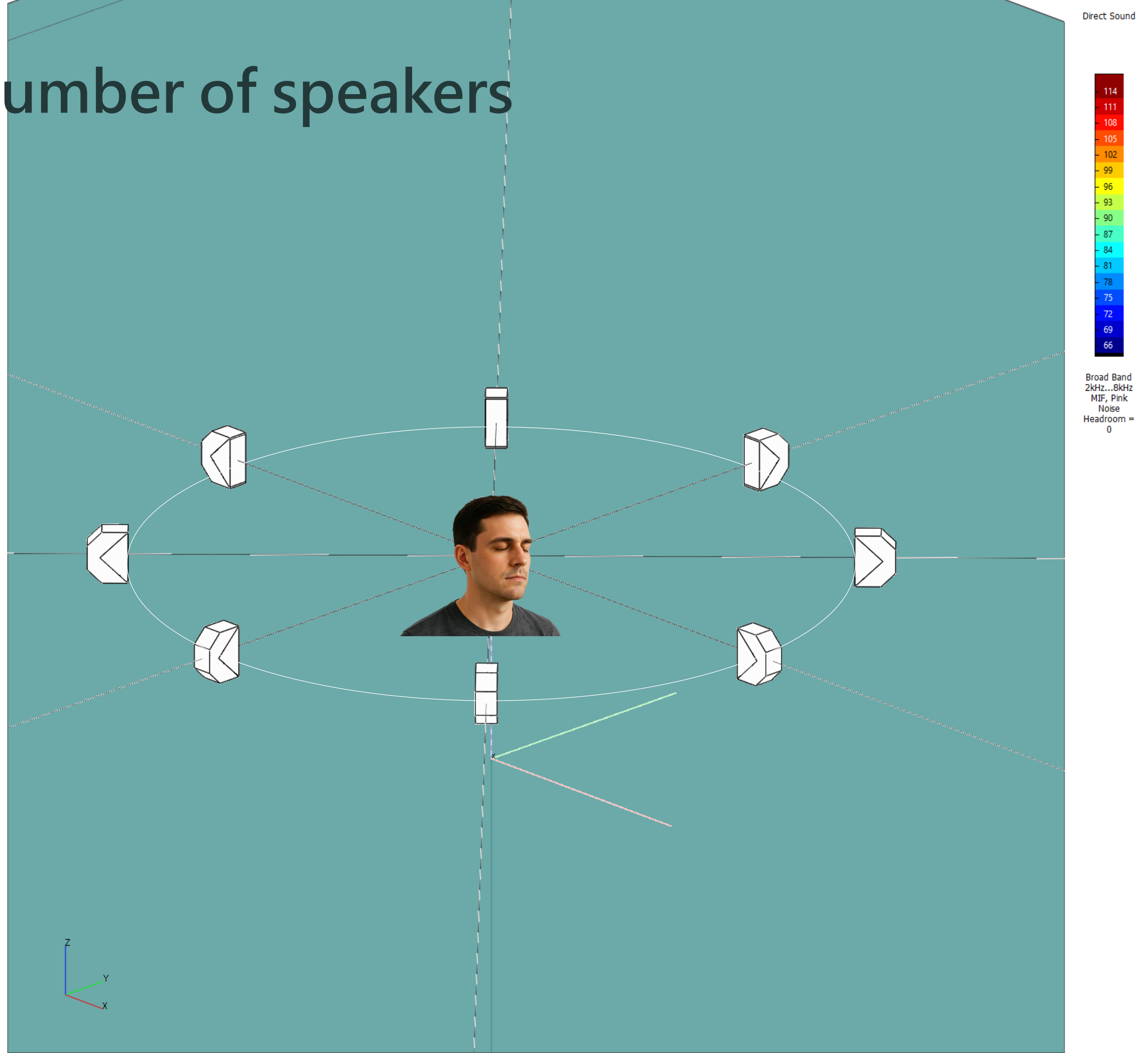

Direct Sound

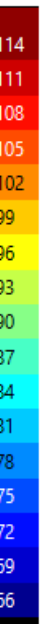

Broad Band
2kHz...8kHz
MIF, Pink
Noise
Headroom =
0

The ITU-R Research: Number of speakers

12 loudspeakers
30° aperture

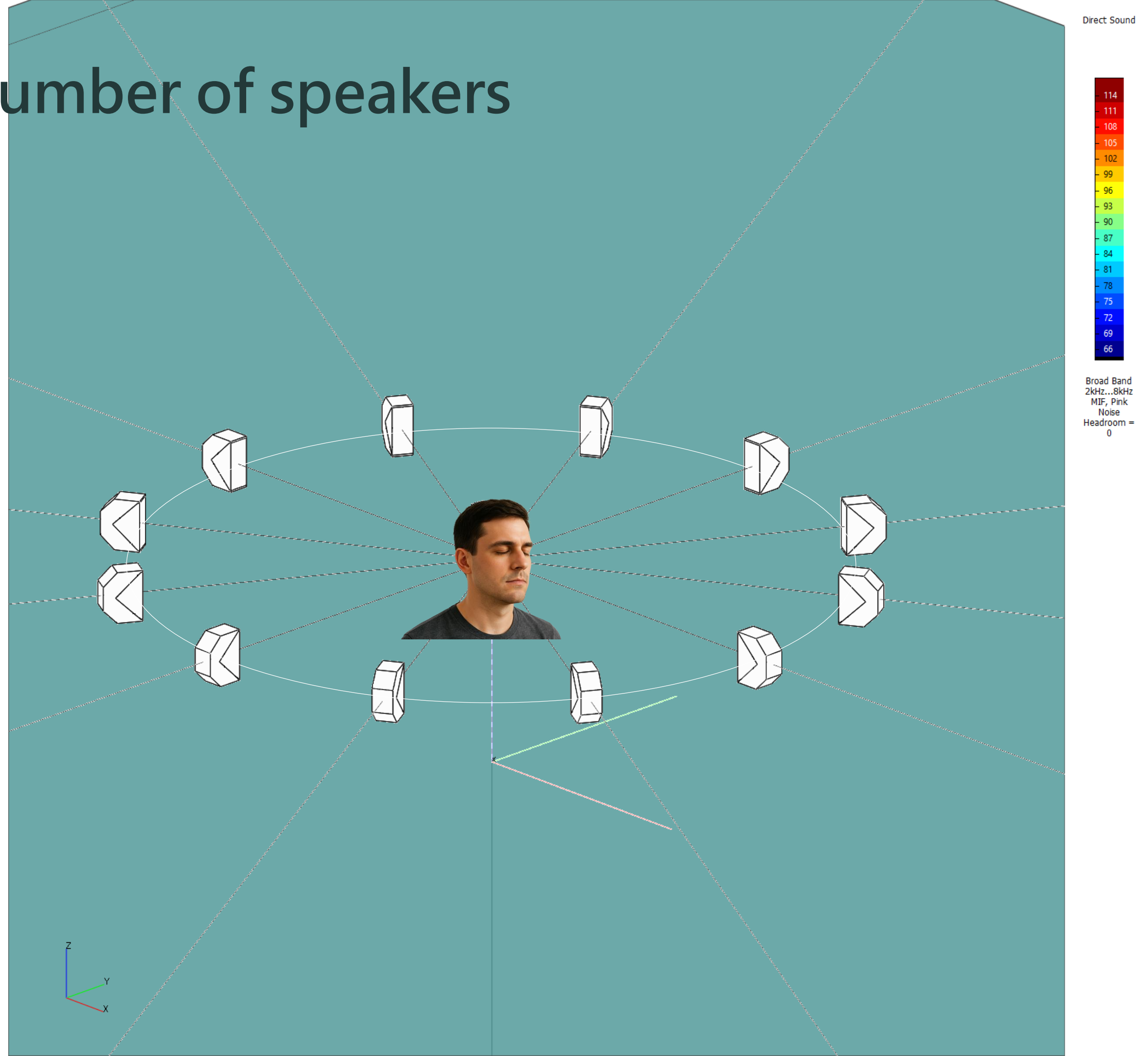
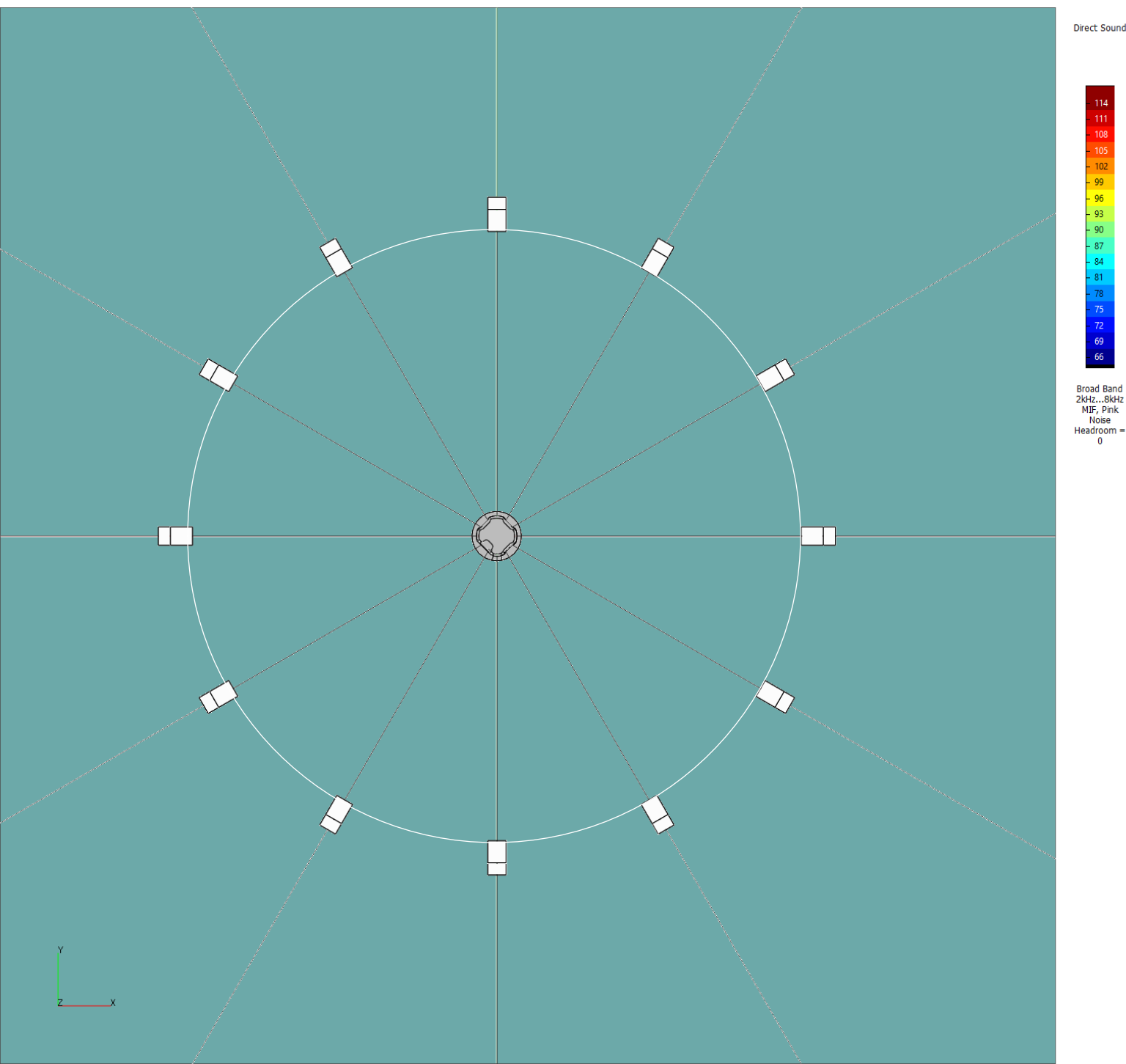

The ITU-R Research: Number of speakers

24 loudspeakers
15° aperture

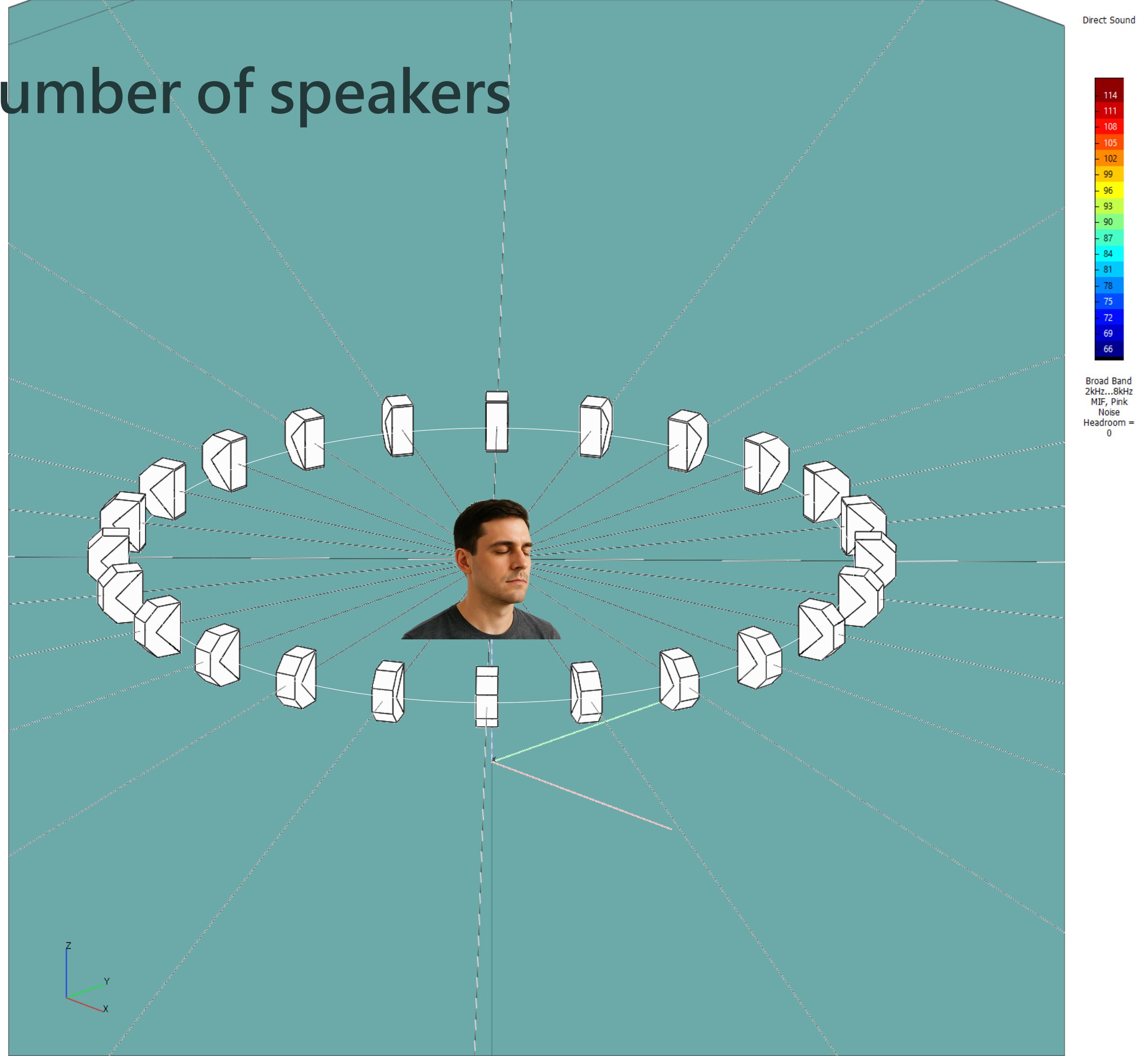
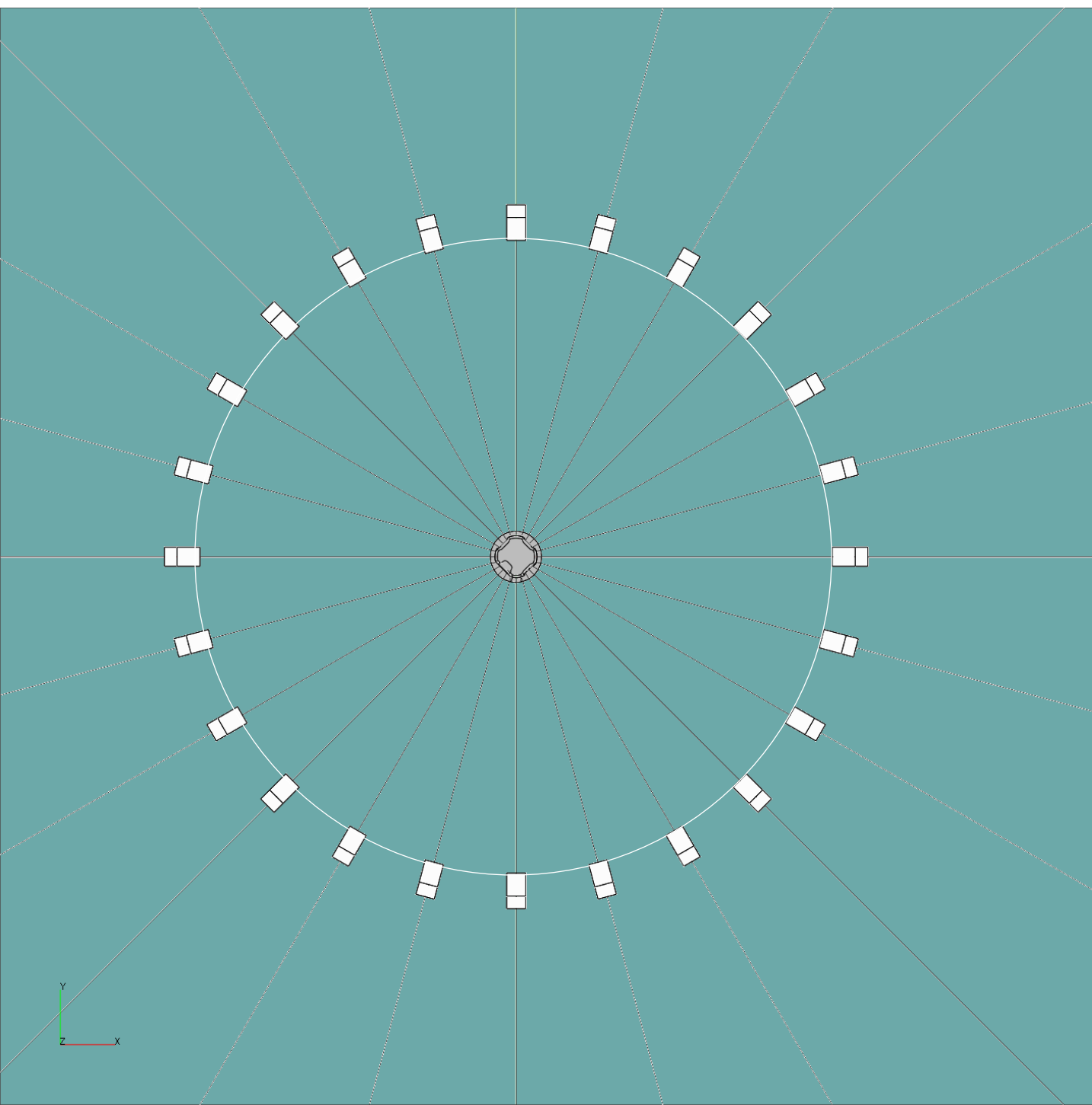

The ITU-R Research: Number of speakers

8 loudspeakers

4 x 2

90° aperture

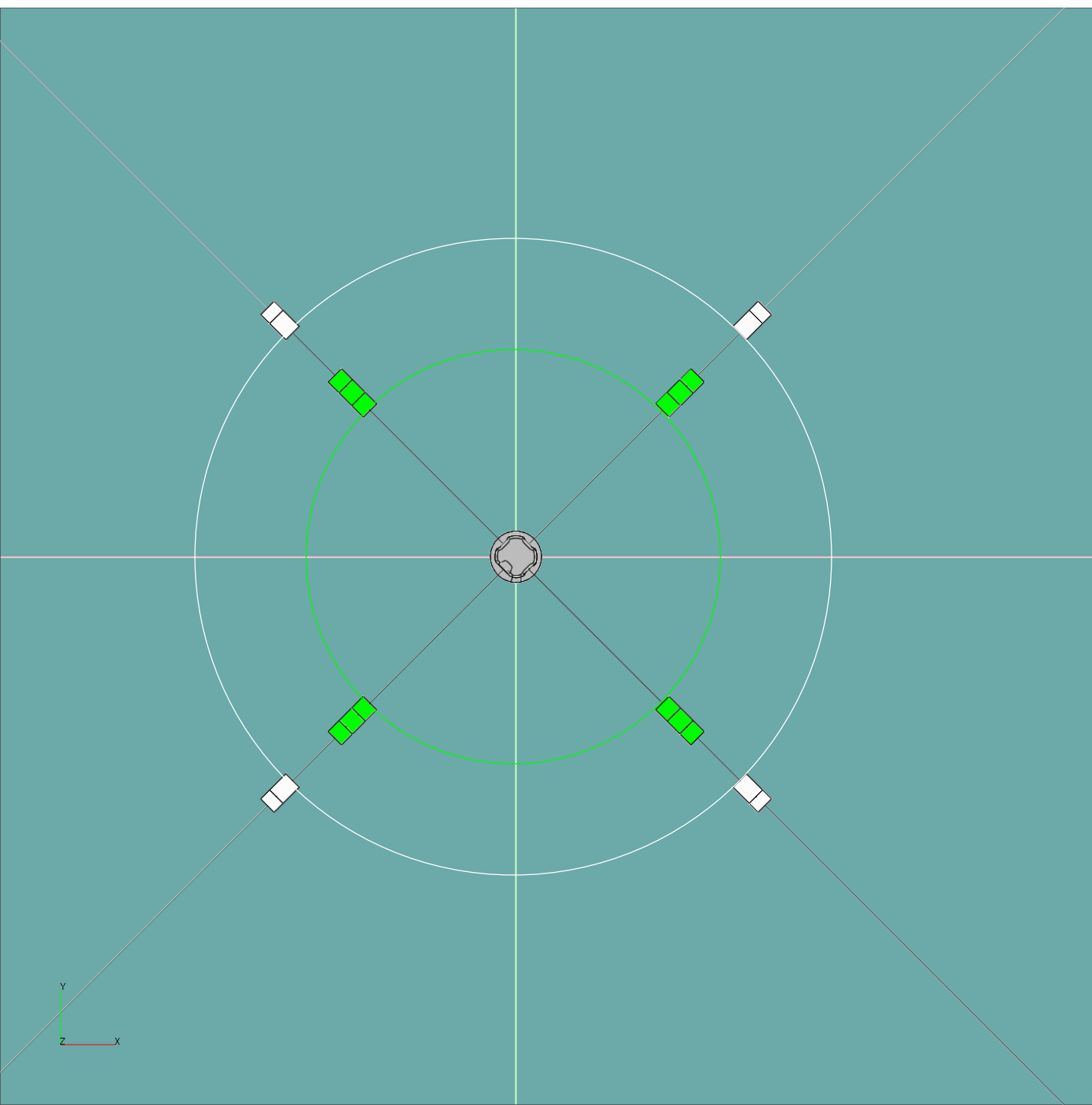

Direct Sound

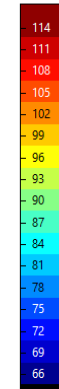

Broad Band
2kHz...8kHz
MIF, Pink
Noise
Headroom =
0

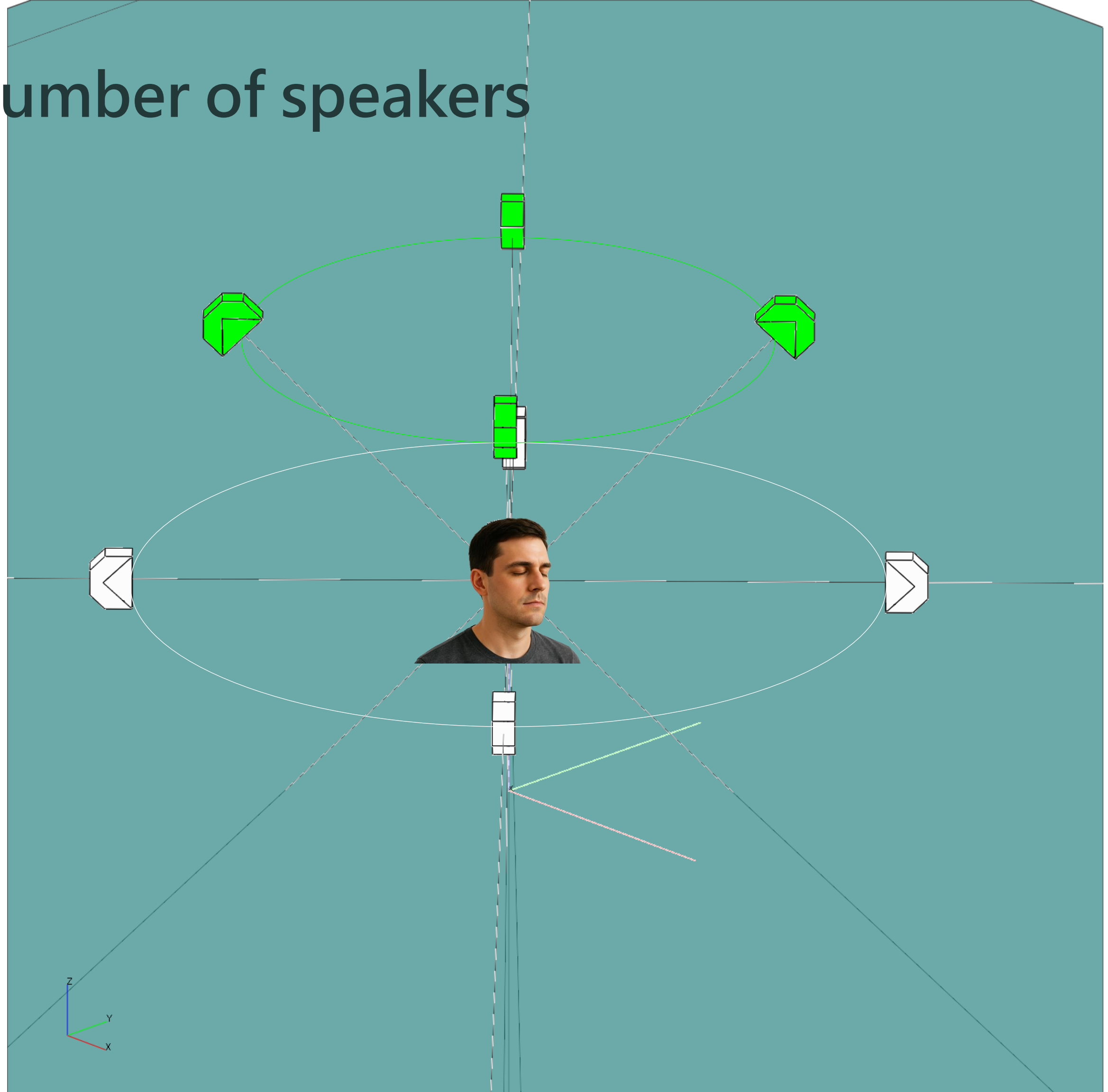

Direct Sound

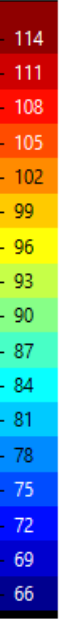

Broad Band
2kHz...8kHz
MIF, Pink
Noise
Headroom =
0

The ITU-R Research: Number of speakers

12 loudspeakers

6 x 2

60° aperture

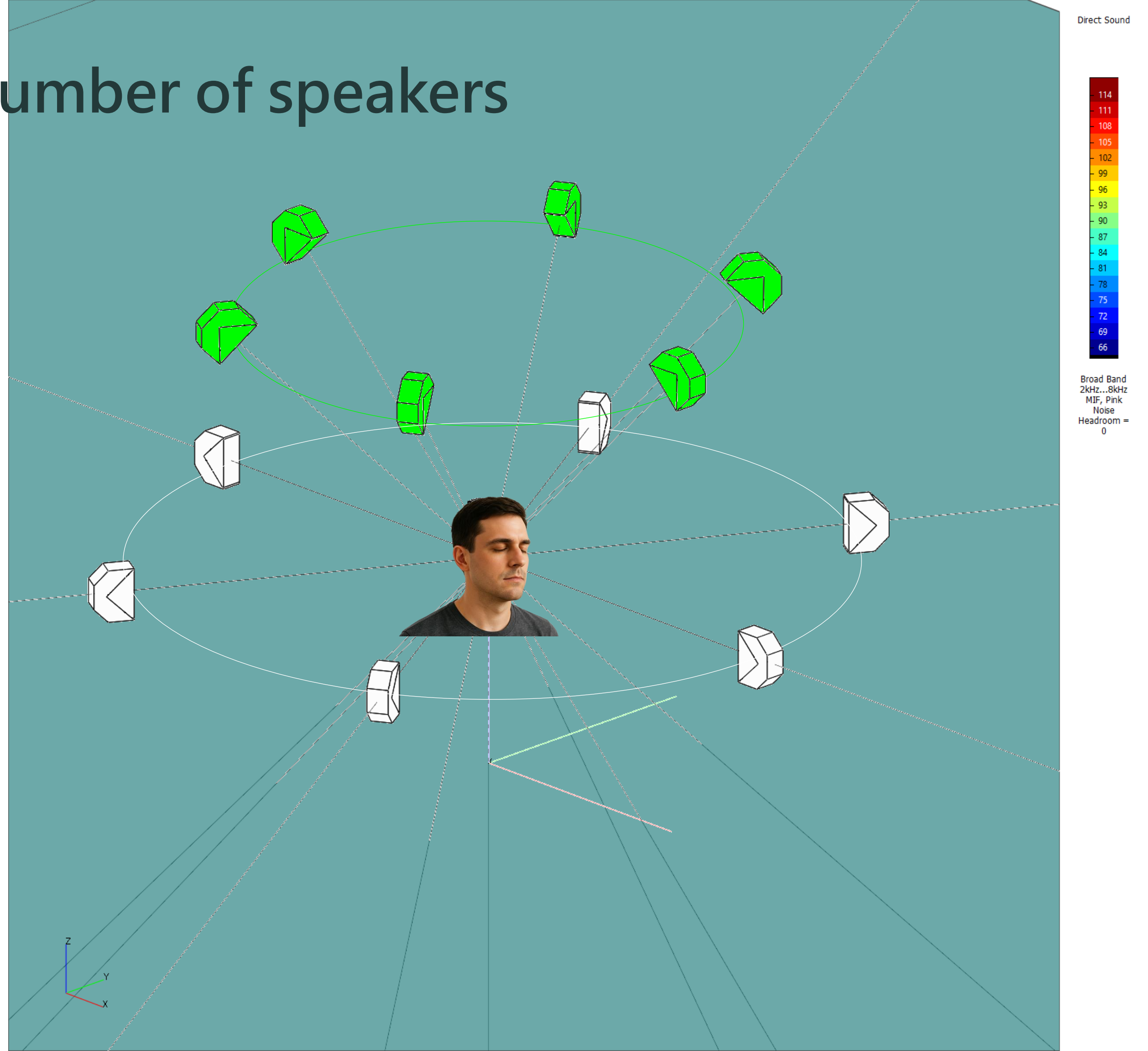
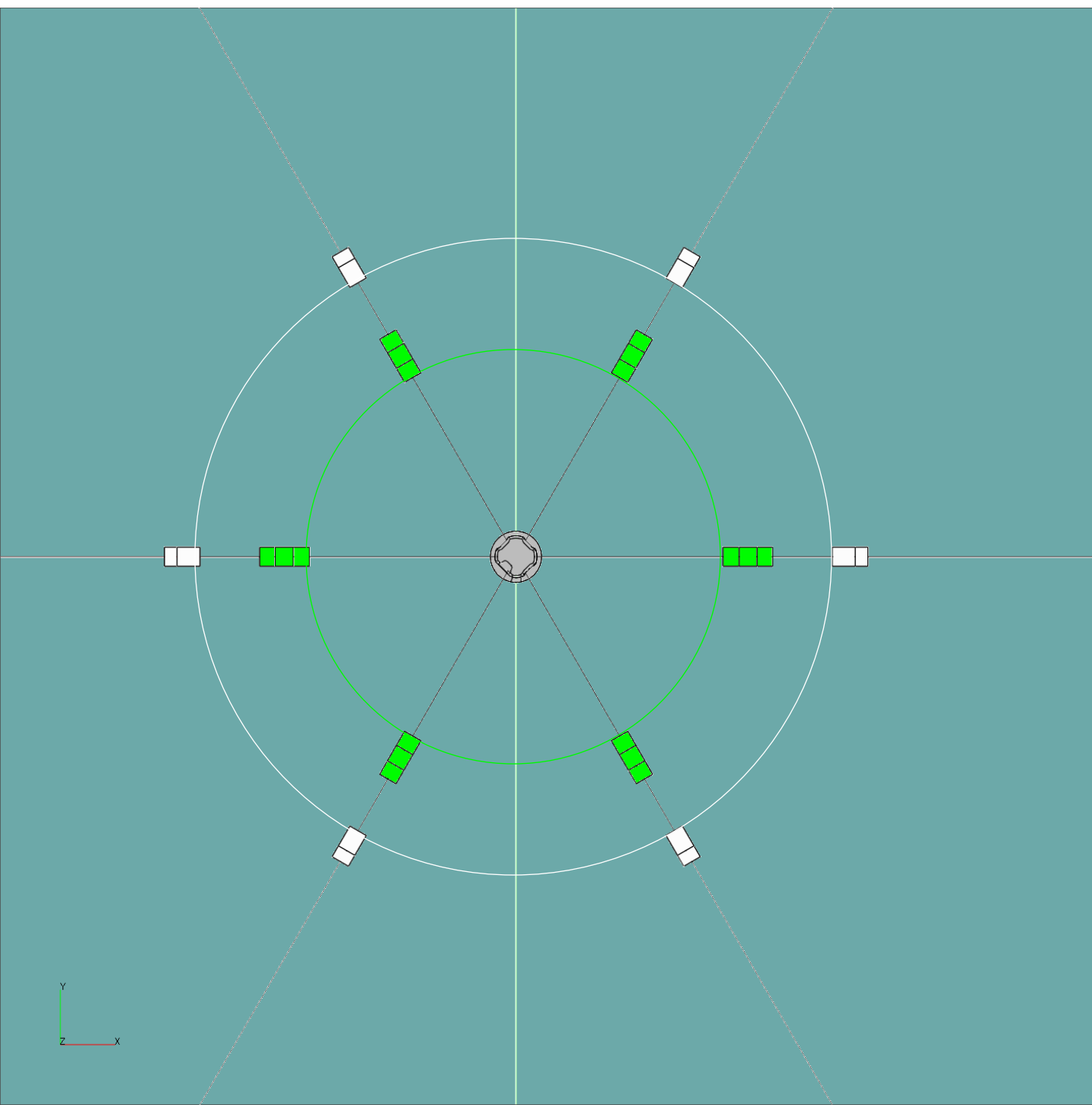

The ITU-R Research: Number of speakers

16 loudspeakers

8 x 2

45° aperture

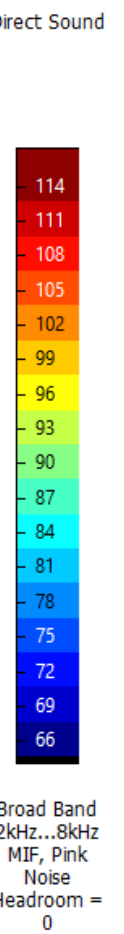
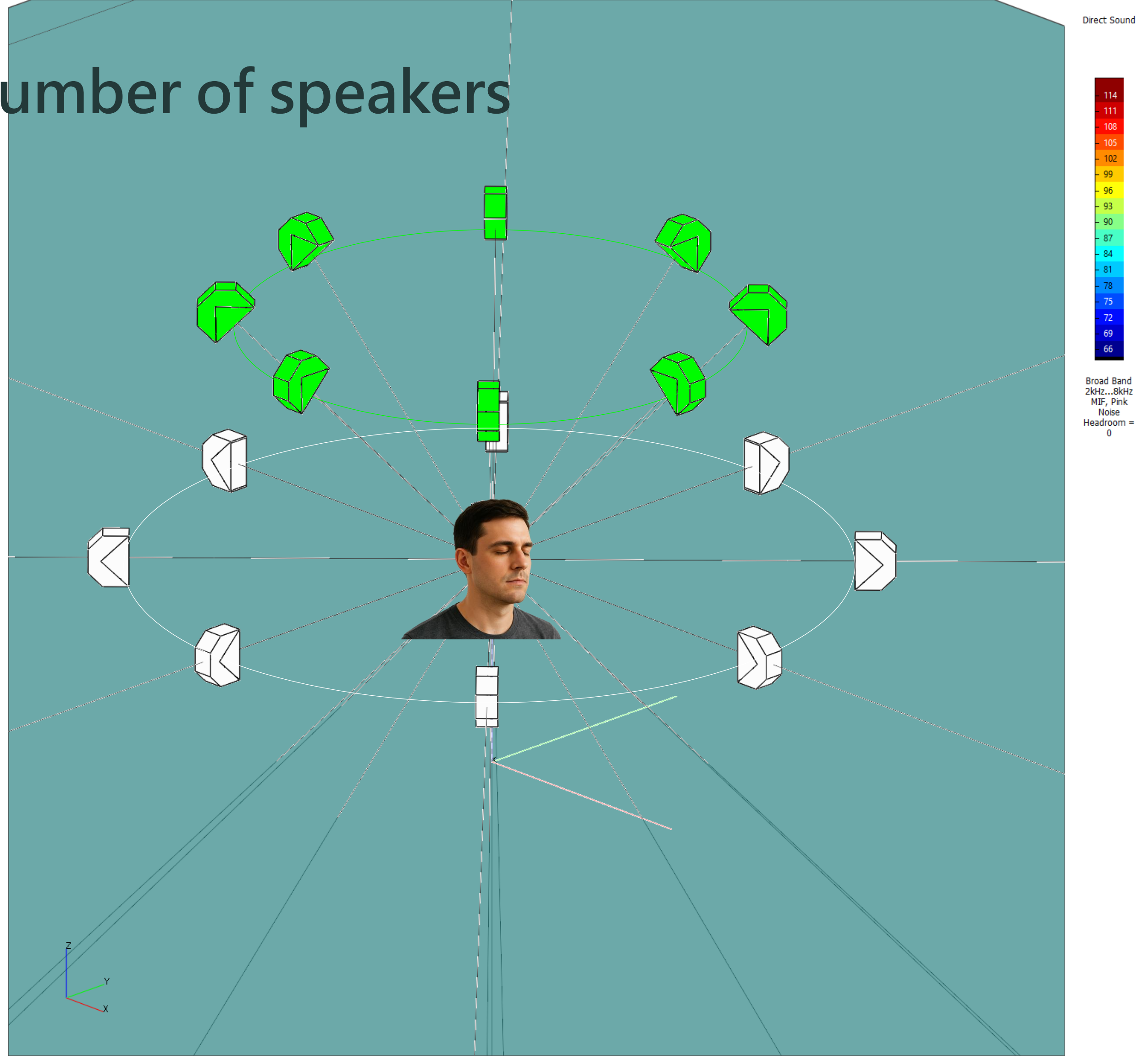
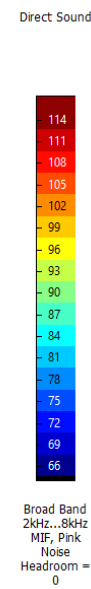
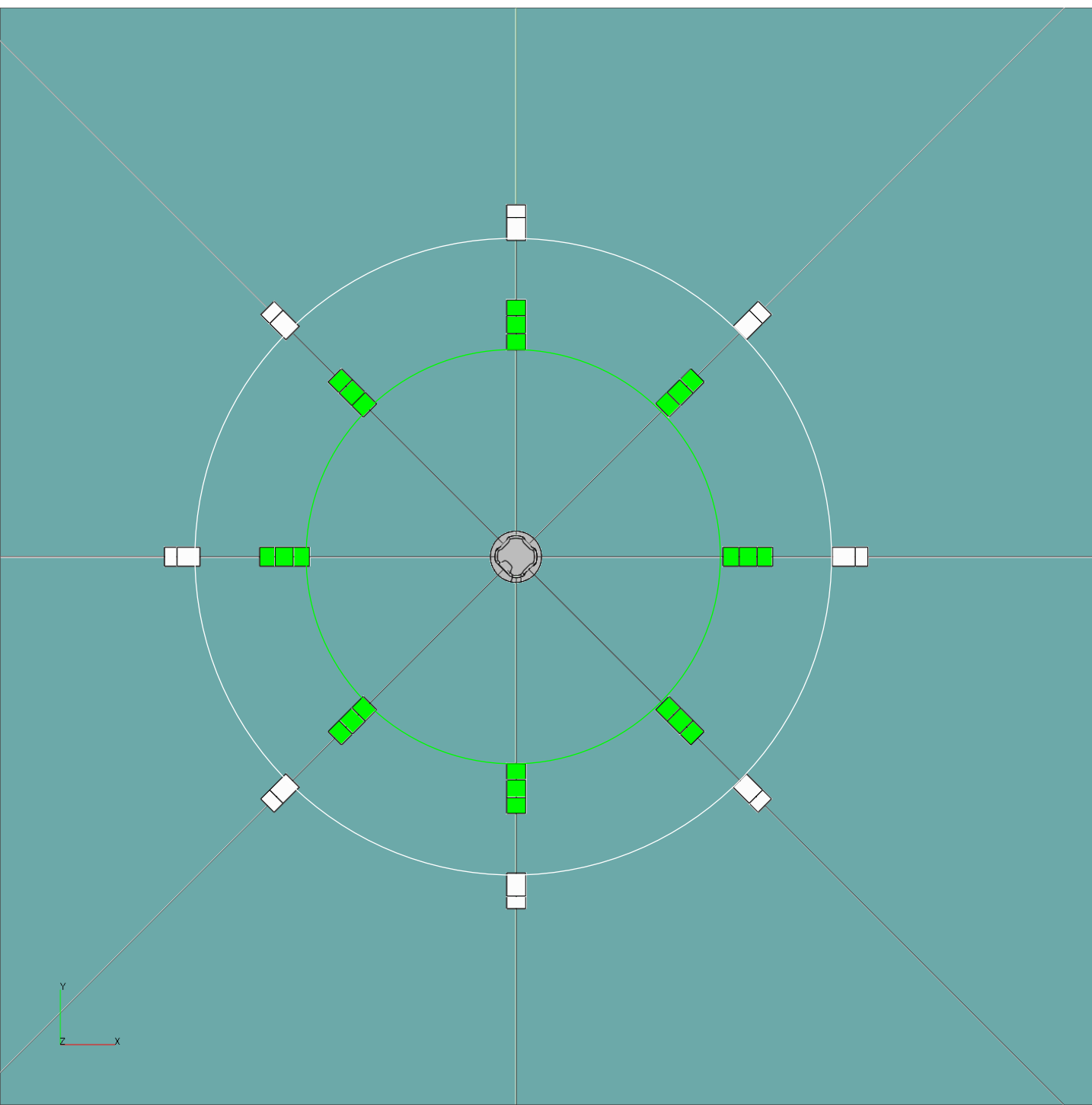

The ITU-R Research: Number of speakers

48 loudspeakers

24 x 2

15° aperture

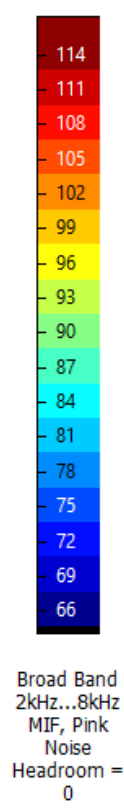
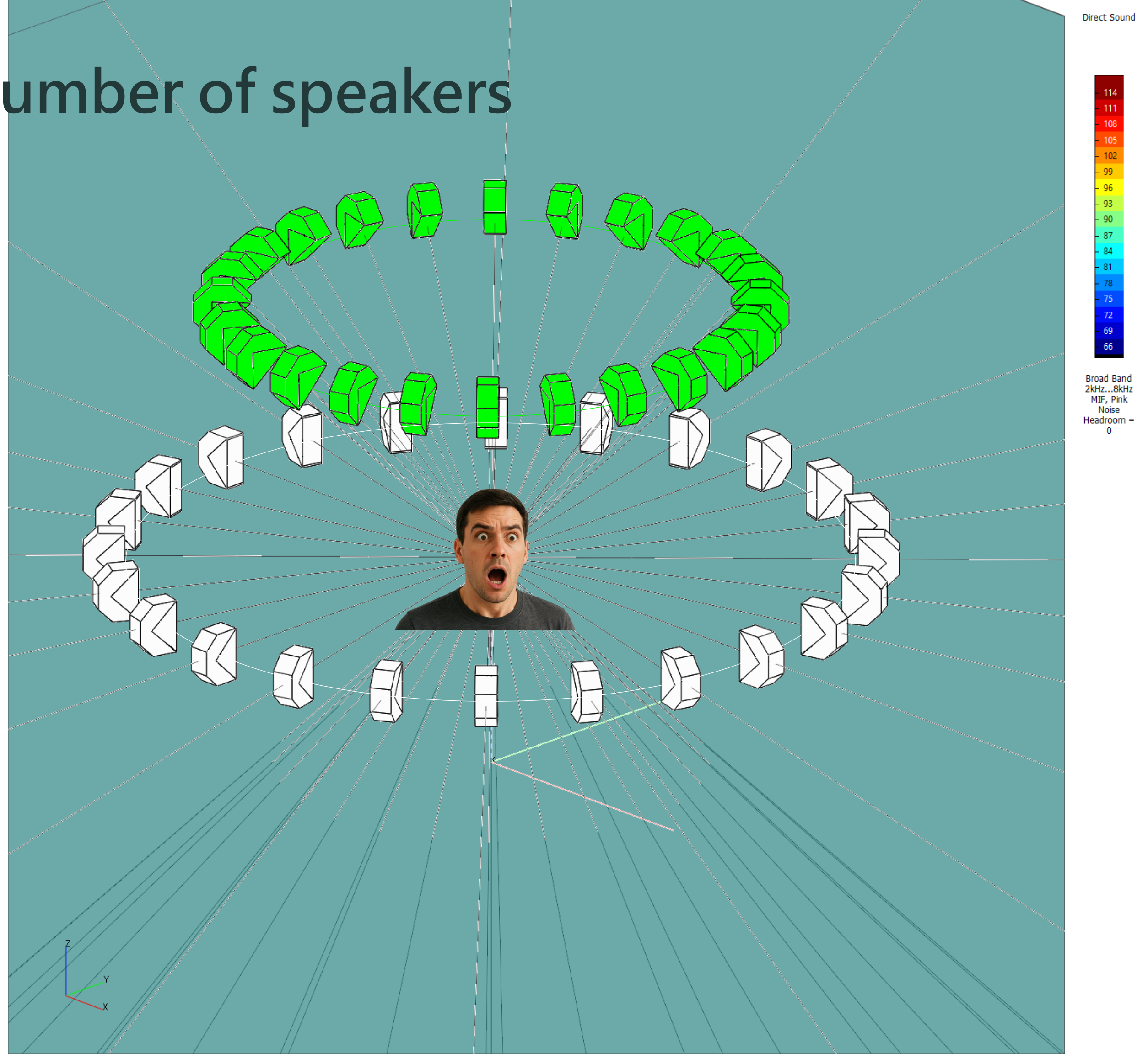
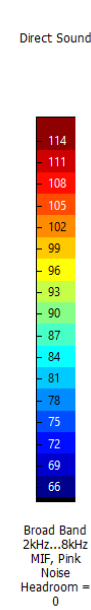
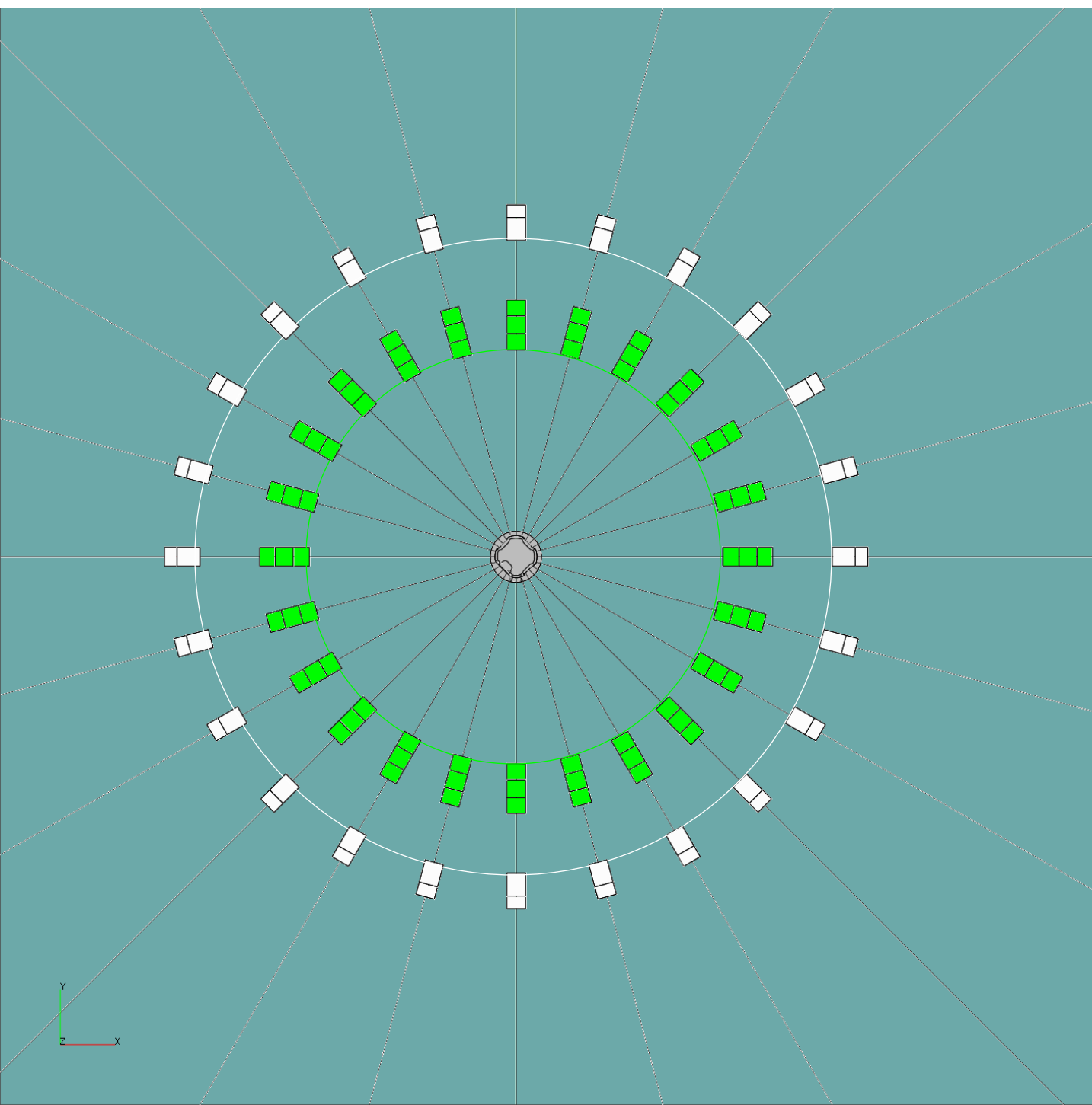

The ITU-R Research

- Extensive studies pinpoint minimum speaker needs for immersion.
- Testing used uncorrelated white noise in controlled settings to measure envelopment.

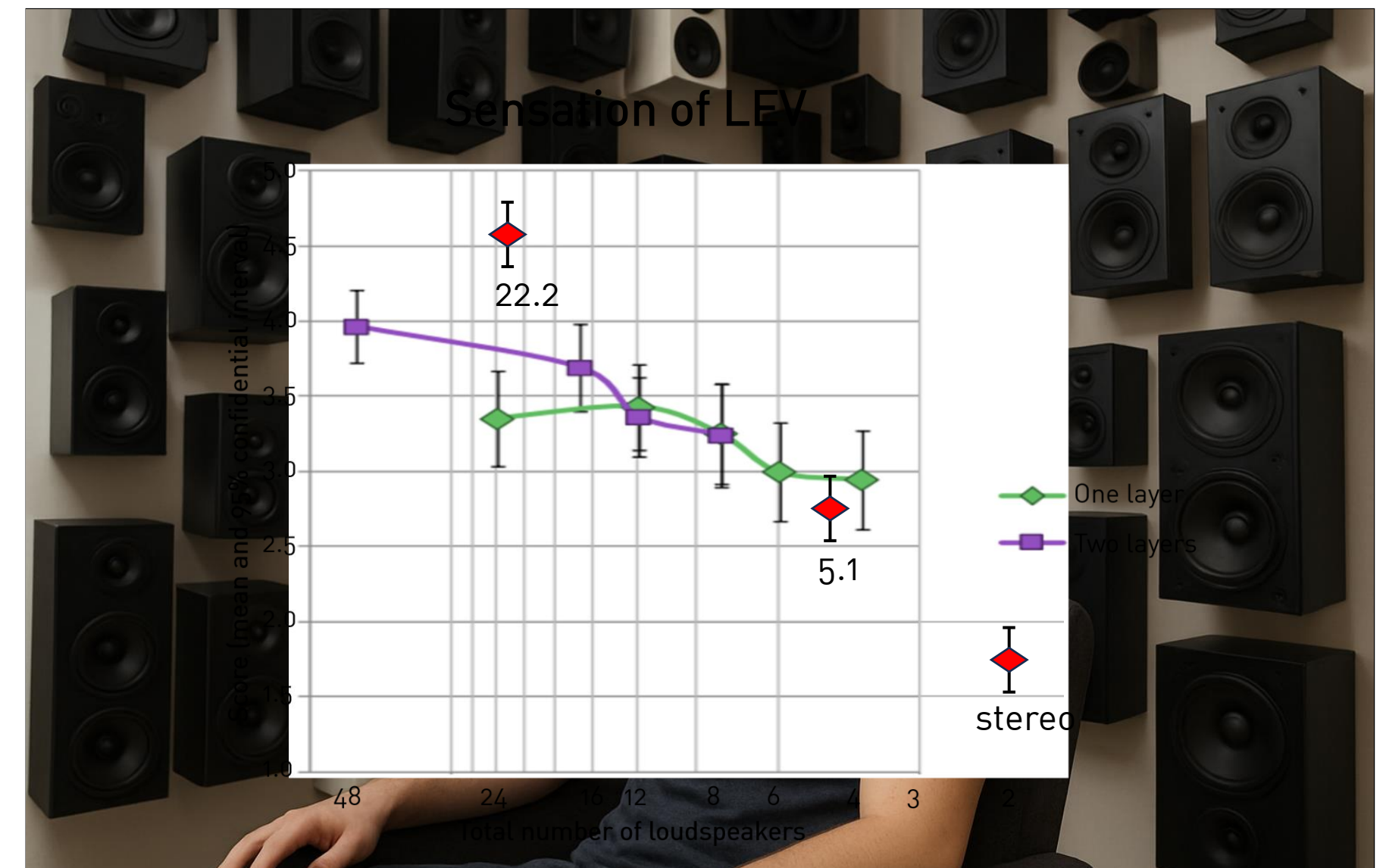
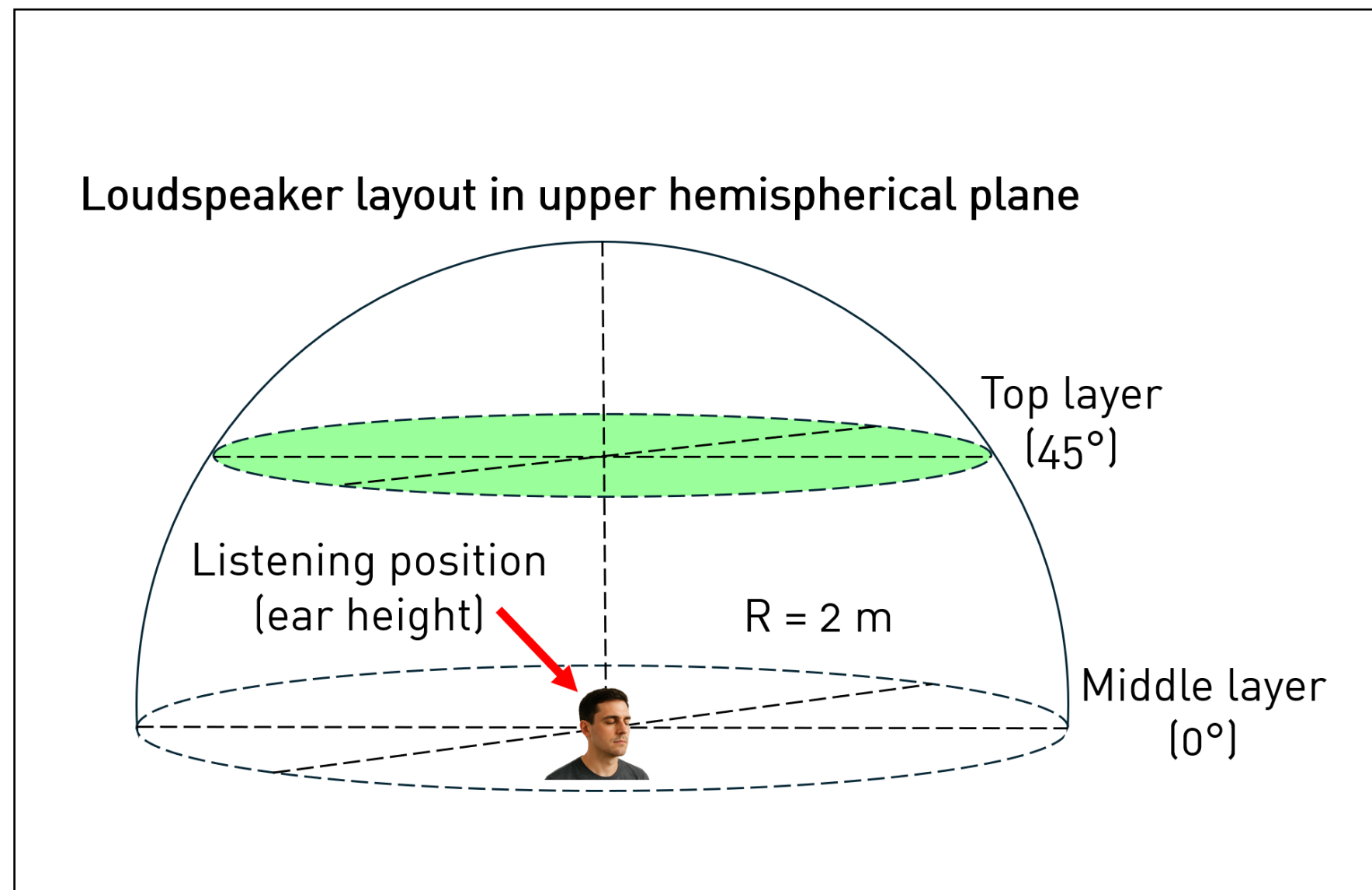
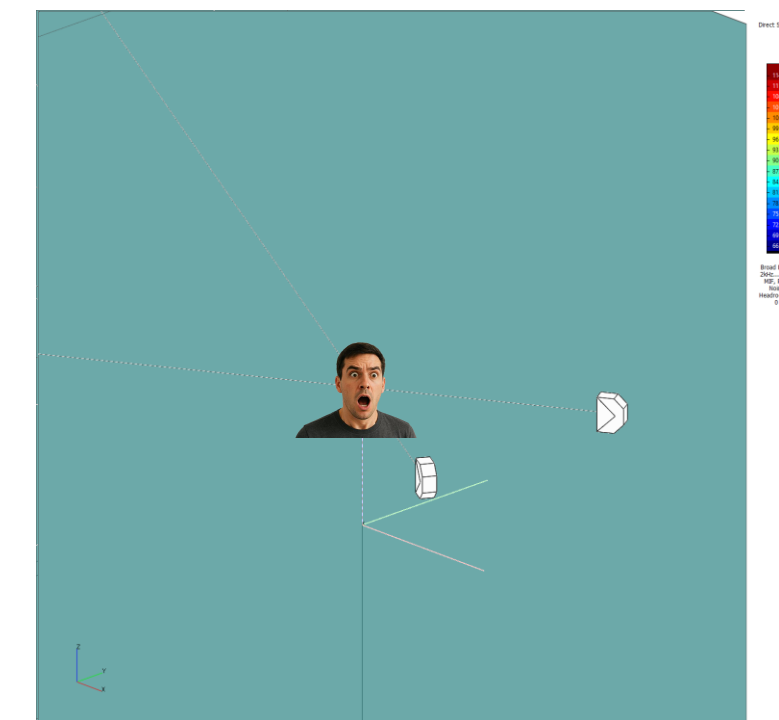

The Sweet Spot revealed

- Studies show critical insights into minimal speaker needs for immersion.
- Testing with ambient noise highlights clear thresholds for envelopment.

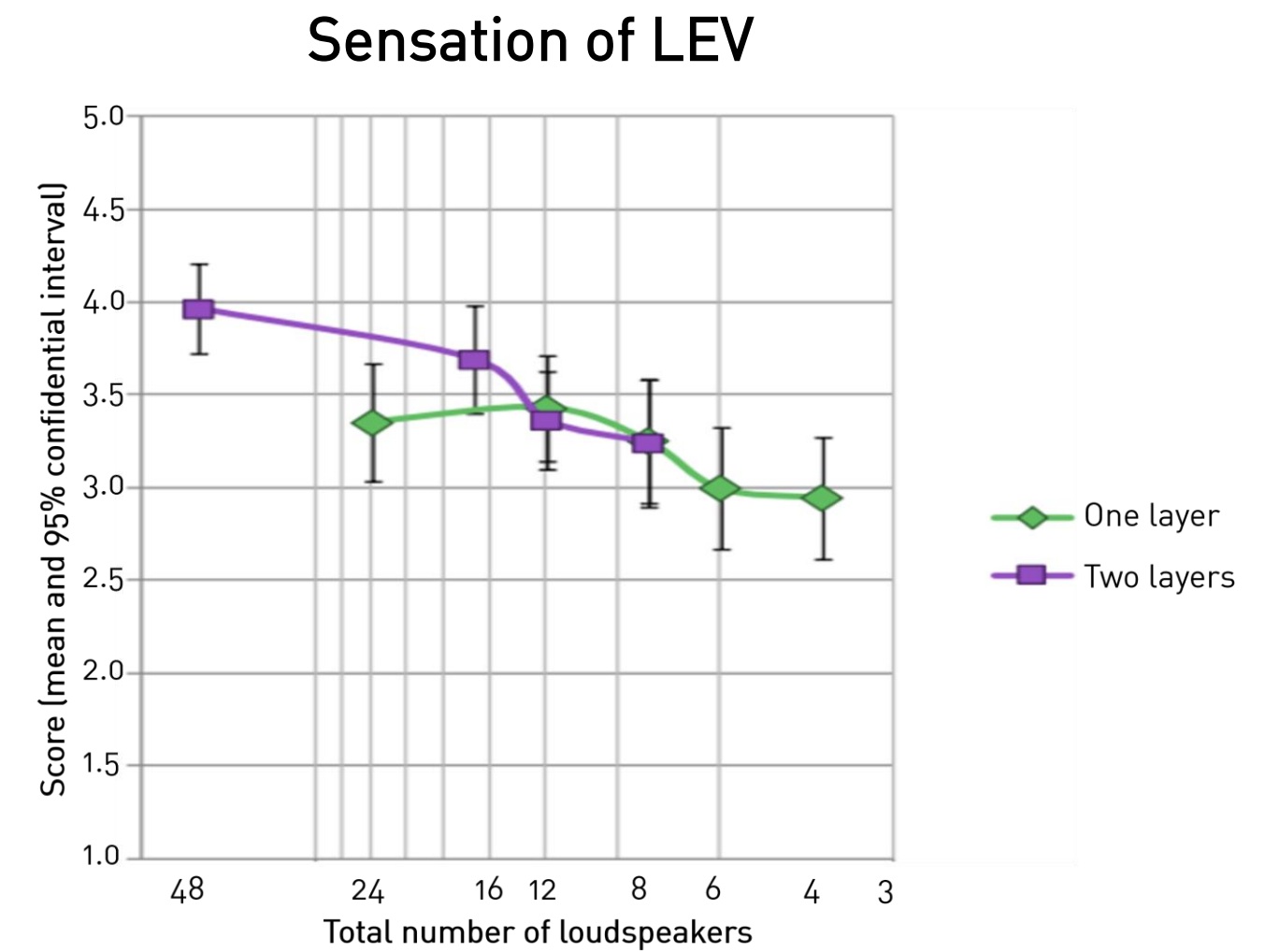

Sweet Spot: 16 speakers (8x2 dual-layer) deliver LEV scores ~4.0, exceeding 5.1 by 25-40%

Minimum Speaker Thresholds

- Horizontal Immersion: 6-8 speakers at 45-60° intervals for basic envelopment (score ~3.0).
- Full 3D Experience: 16 speakers (8x2 dual-layer) at 45° for scores ~4.0; stable across wide areas.
- Vs. 5.1: Dual-layer boosts "rich envelopment" by 1.2-1.4 points.

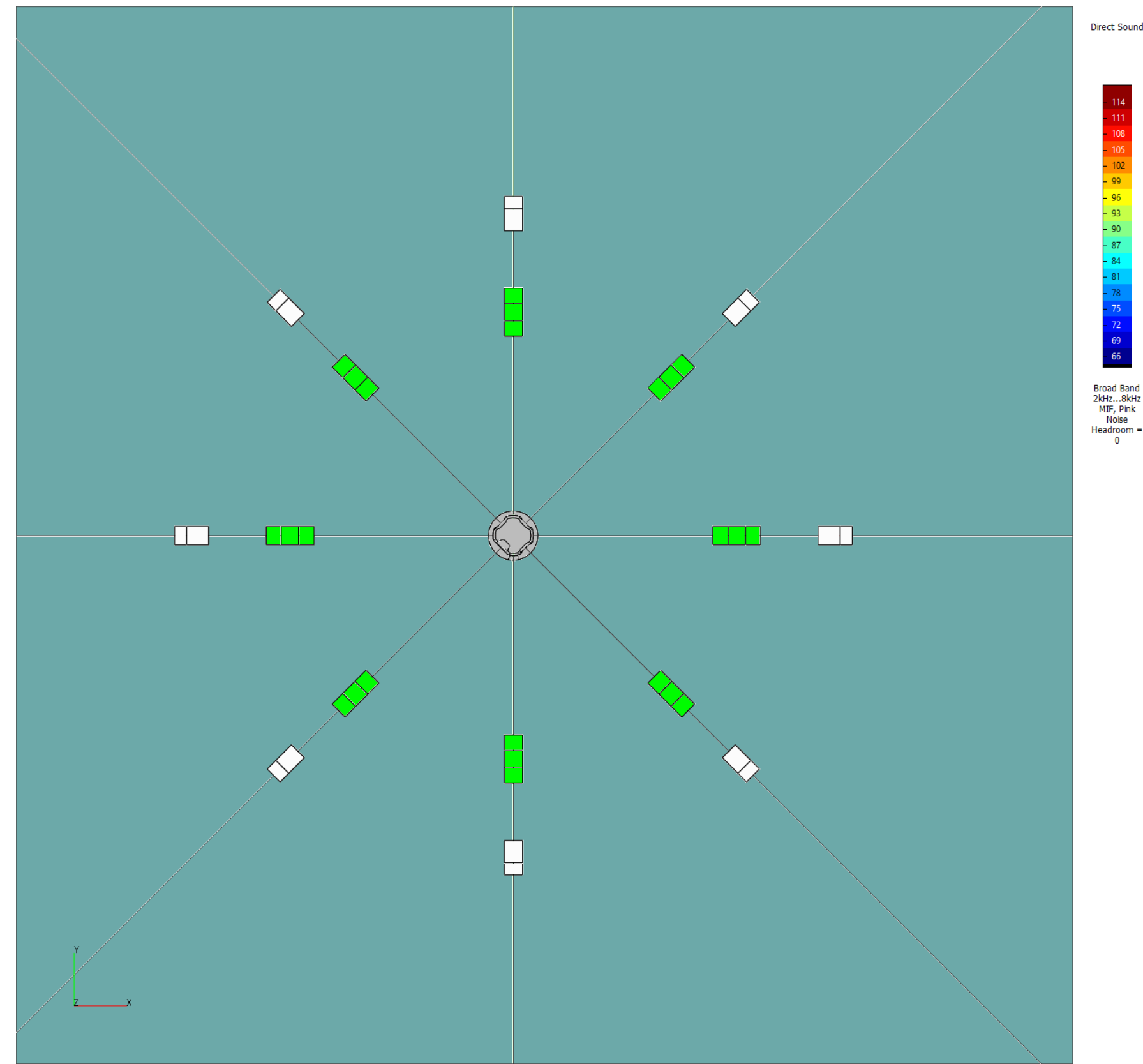

Single Layer vs. Dual Layer Performance

Single Layer (Middle Height)

- LEV saturates at 12 channels
- Diminishing returns beyond 12 channels
- Limited vertical spatial impression

Dual Layer (Middle + Top)

- Continued LEV improvement with more channels
- Enhanced 3D spatial impression
- Better envelopment at all channel counts

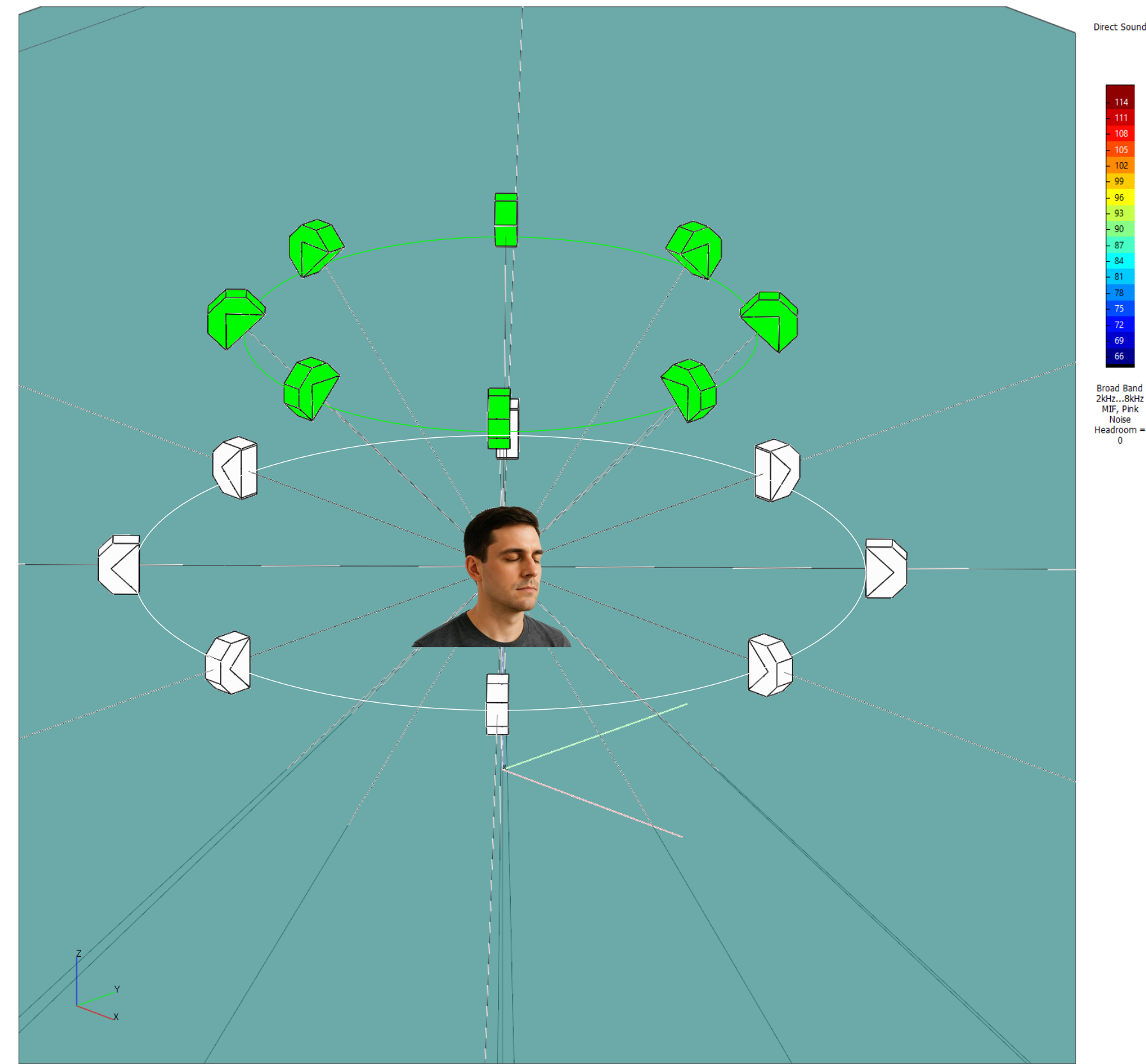

Optimal Spacing & Saturation

- Best Spacing: 30-45° intervals for stable phantom imaging (error <math><10^\circ</math>).
- Saturation: No gains beyond 16 speakers; diminishing returns after 12 in single-layer.
- Practical Pick: 45° spacing balances precision and ease.

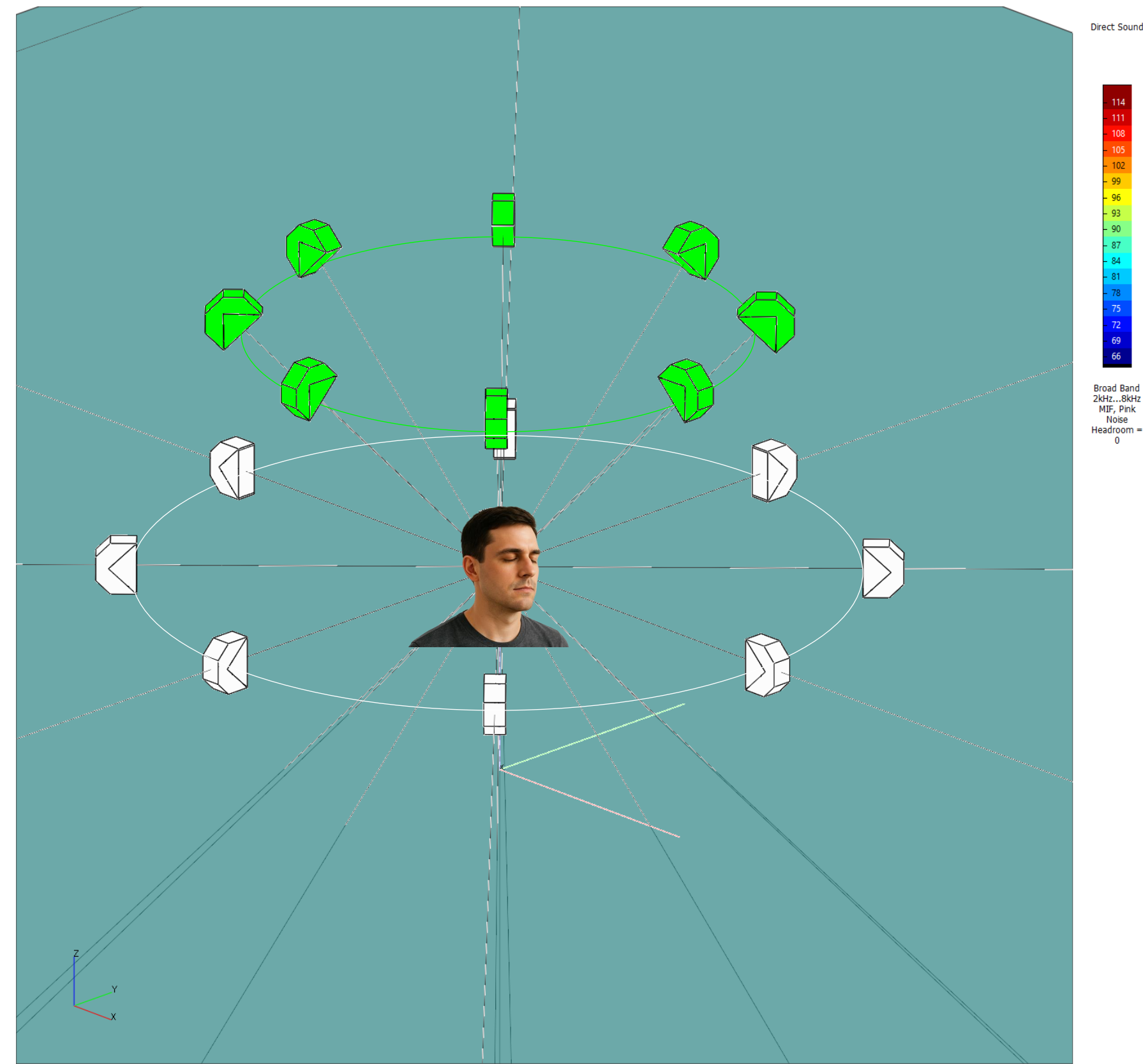

Why 16 Outperforms 22.2 for Broadcast

22.2

Exceptional... But impracticable?

LEV ~4.5

complex (24+ speakers, high install cost)

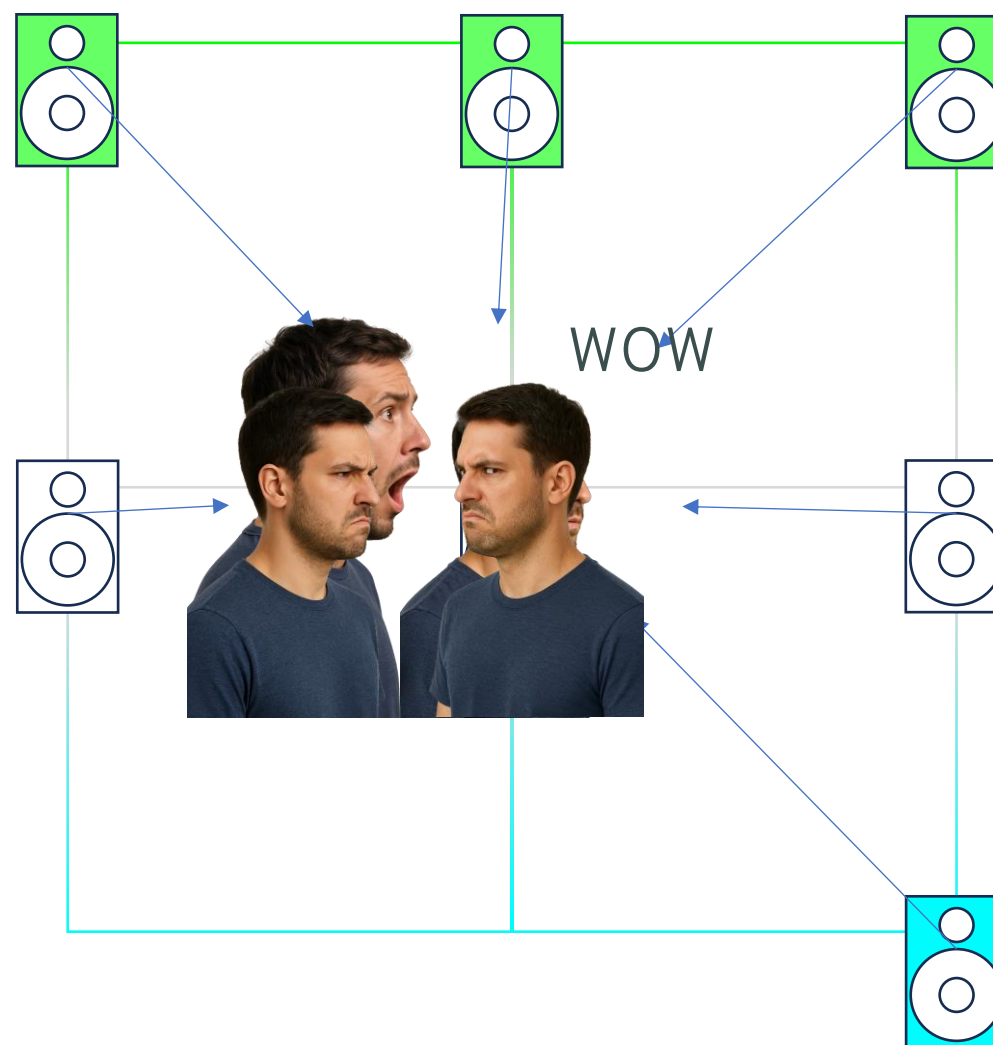
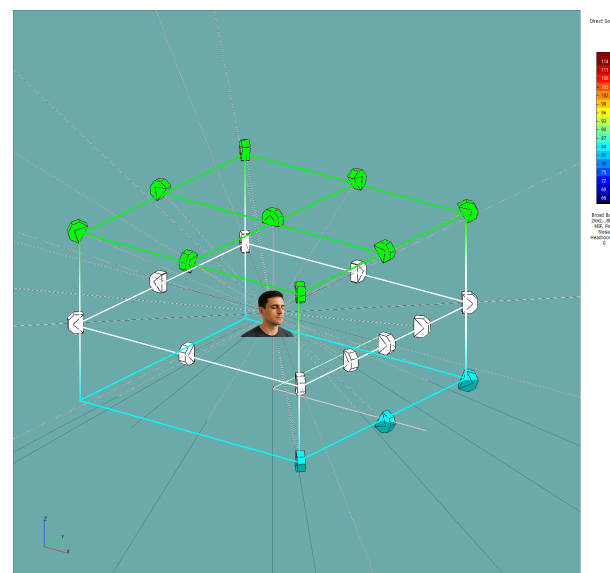

16

Matches 80-90% immersion

LEV ~3.5

Less complex (33% fewer speakers; ideal for live)

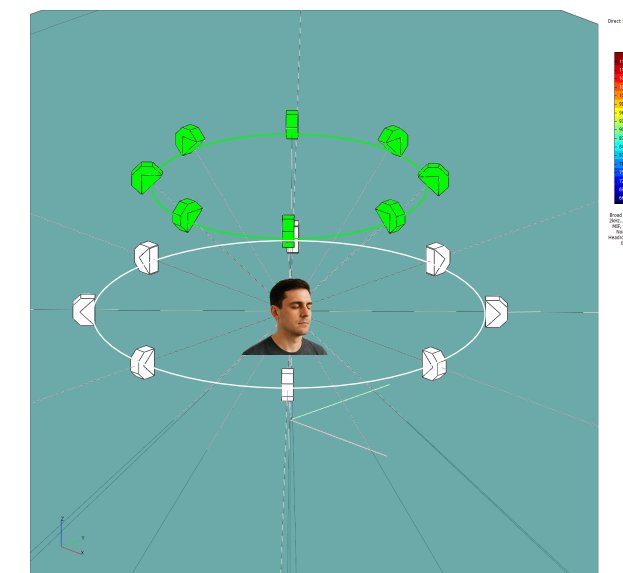

Difference: Barely noticeable in real-world use.

Why 16 Outperforms 22.2 for Broadcast

22.2

Exceptional... But impracticable?

LEV ~4.5

complex (24+ speakers, high install cost)

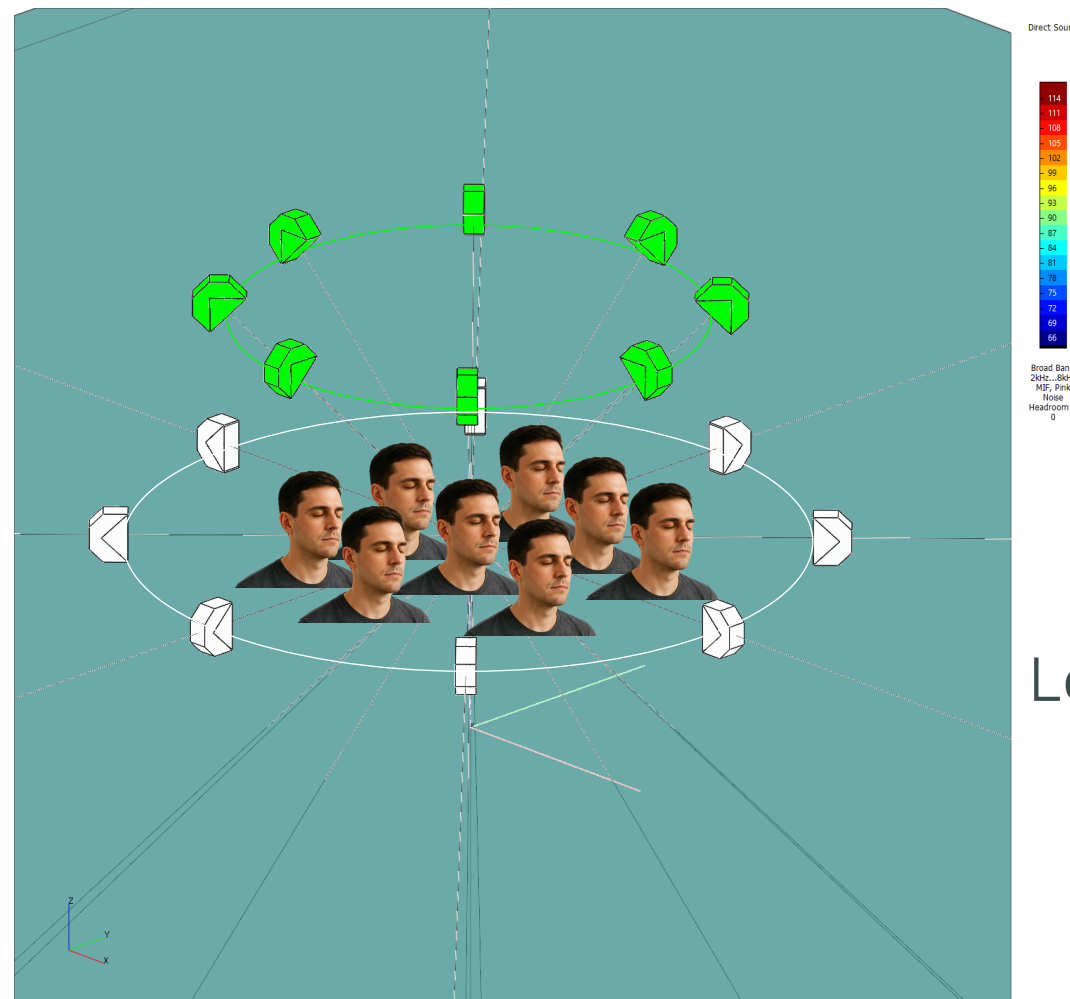
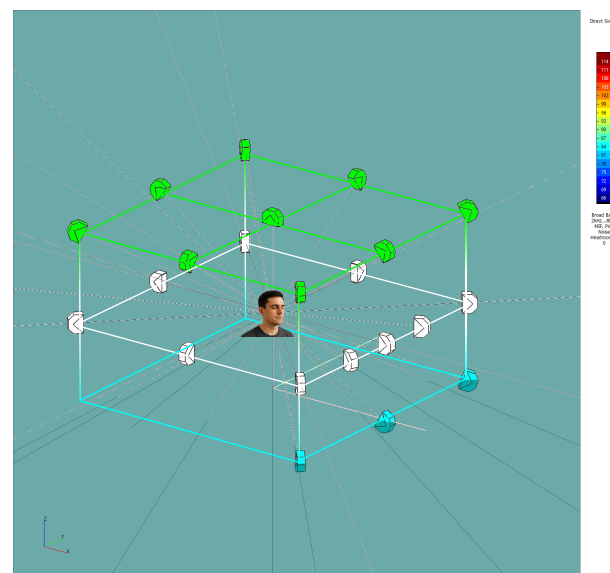

Difference: Barely noticeable in real-world use.

16

Matches 80-90% immersion

LEV ~3.5

Less complex (33% fewer speakers; ideal for live)

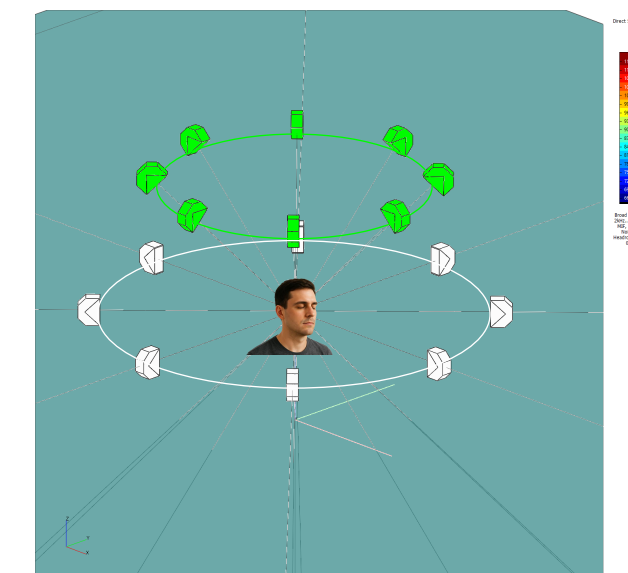

SDC 2025: Steiner Saal

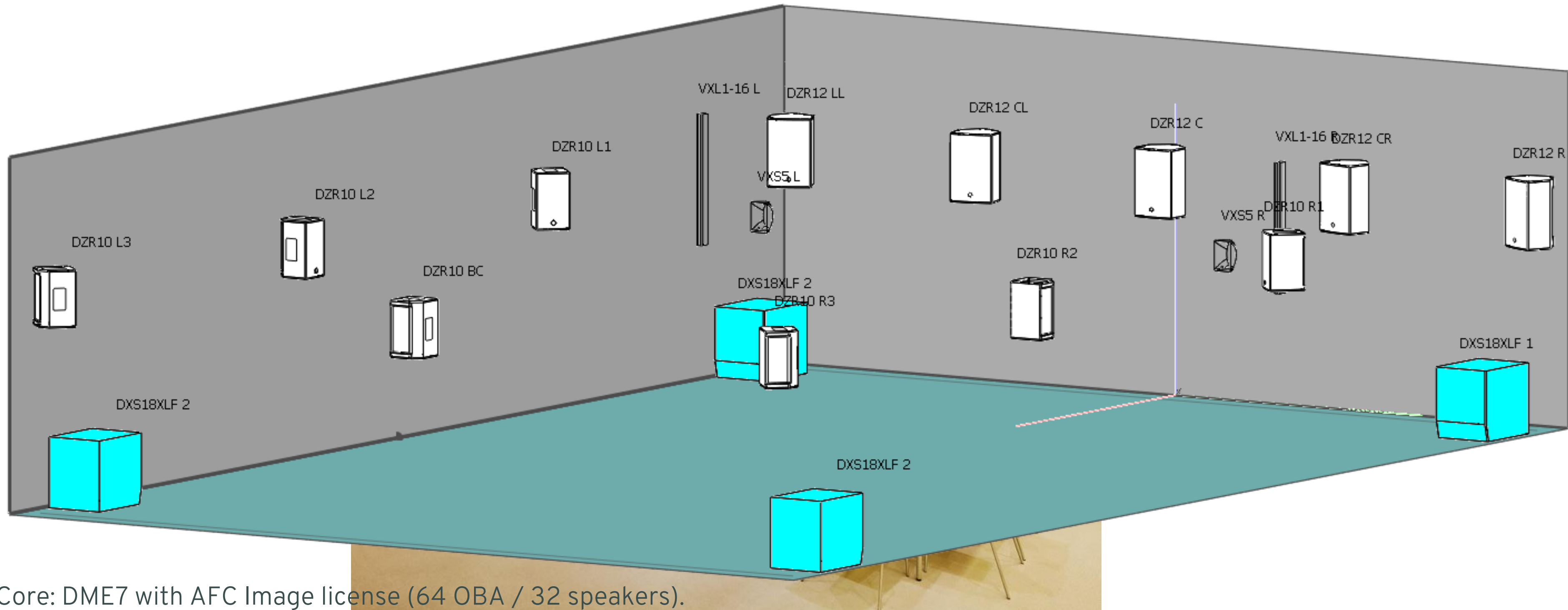

- Core: DME7 with AFC Image license (64 OBA / 32 speakers).
- Front: 5x DZR12-D (direct imaging).
- Surround: 7x DZR10-D (13°-45° aperture).
- Subs: 4x DXS18XLF-D (bass support).

SDC 2025: Steiner Saal

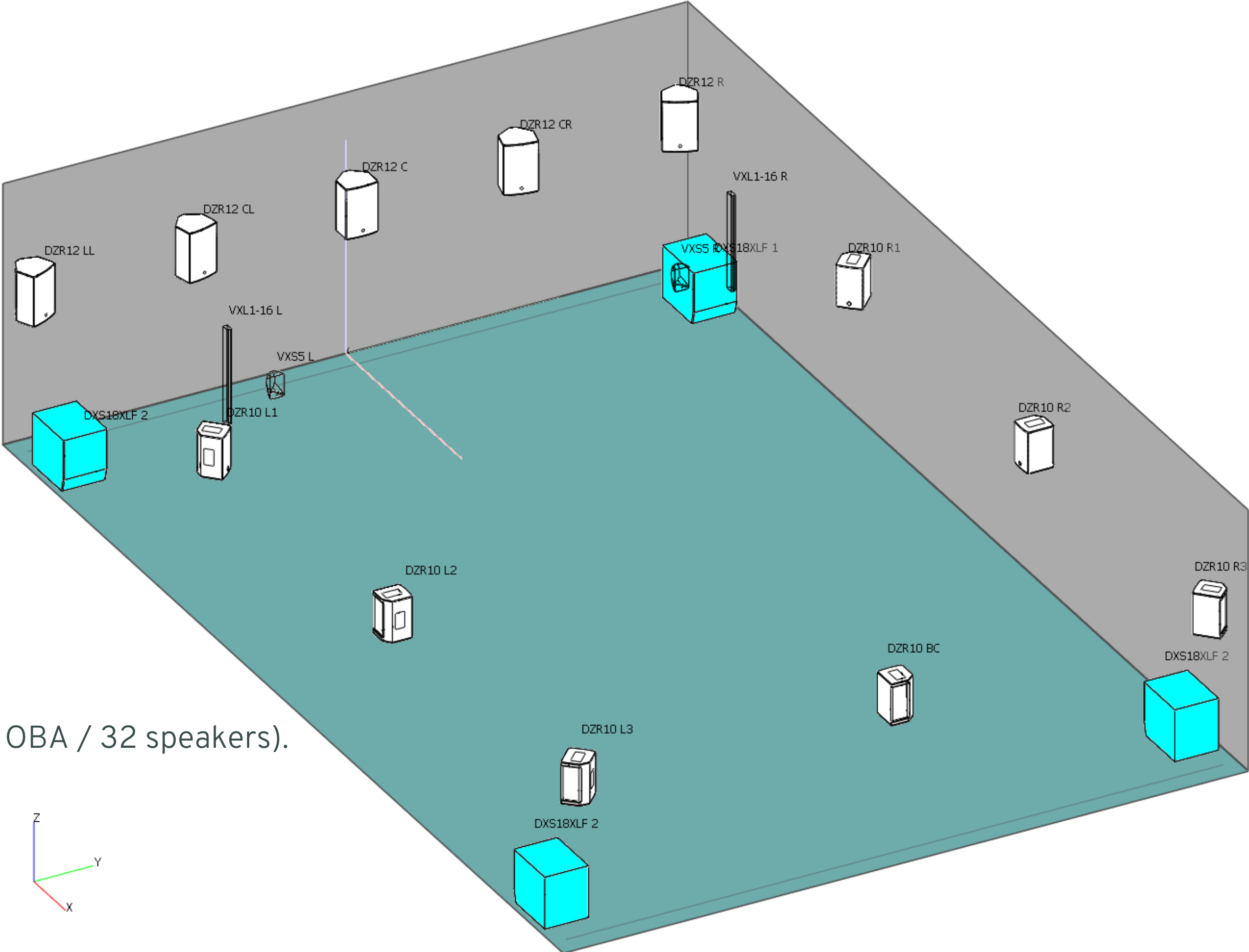
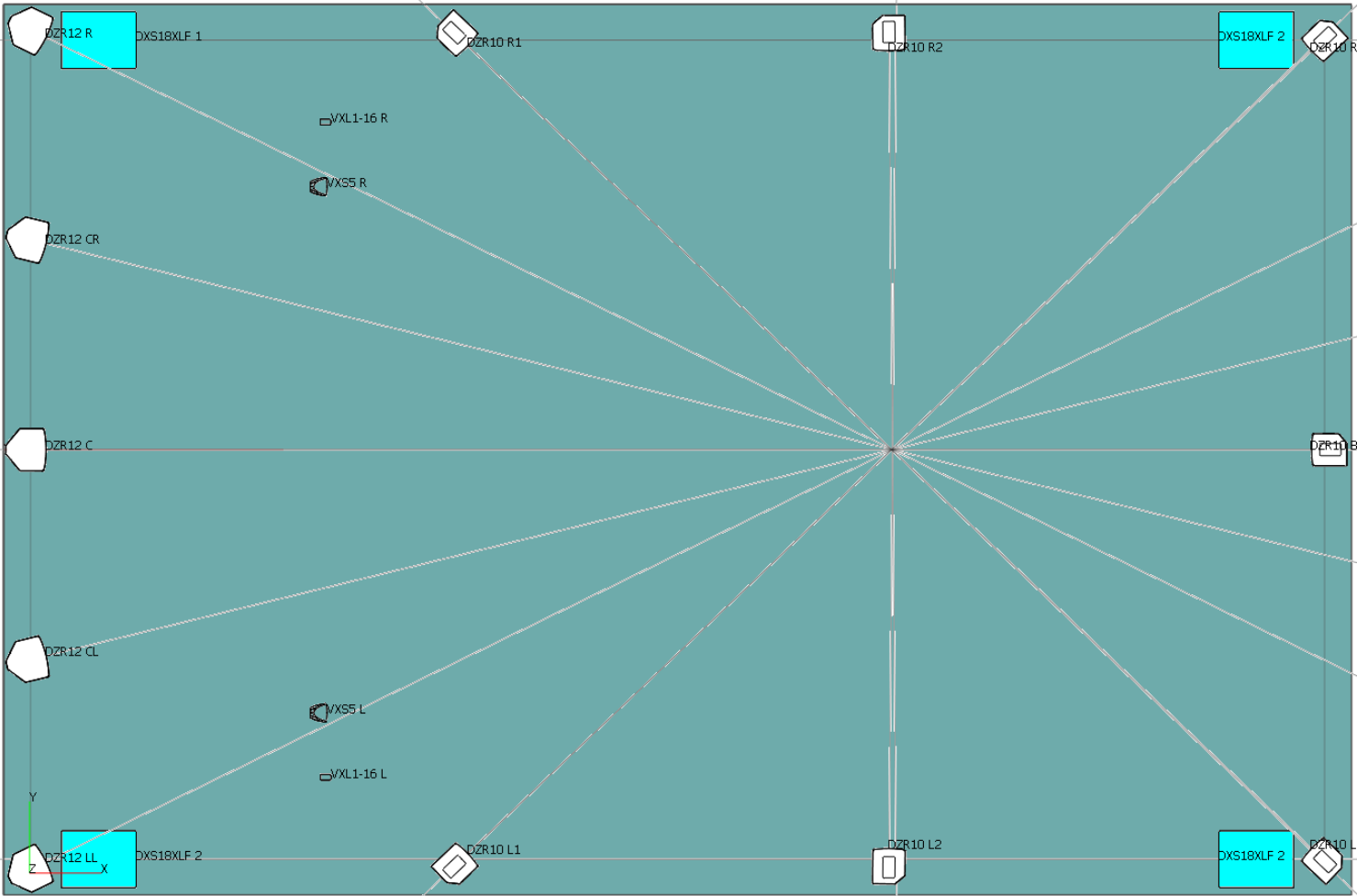

- Core: Yamaha DME7 with AFC Image license (64 OBA / 32 speakers).
- Front: 5x DZR12-D (direct imaging).
- Surround: 7x DZR10-D (13°-45° aperture).
- Subs: 4x DXS18XLF-D (bass support).

The Answer: Immersive is Easier Than You Think

Your 16-speaker setup represents the optimal balance between immersive quality and practical implementation. Research confirms this configuration provides:

- Significant LEV enhancement over 5.1
- Stable phantom imaging across the listening area
- Manageable complexity for live production
- Future-ready for advanced audio formats

Immersive audio isn't about having the most speakers—it's about having enough in the right places.

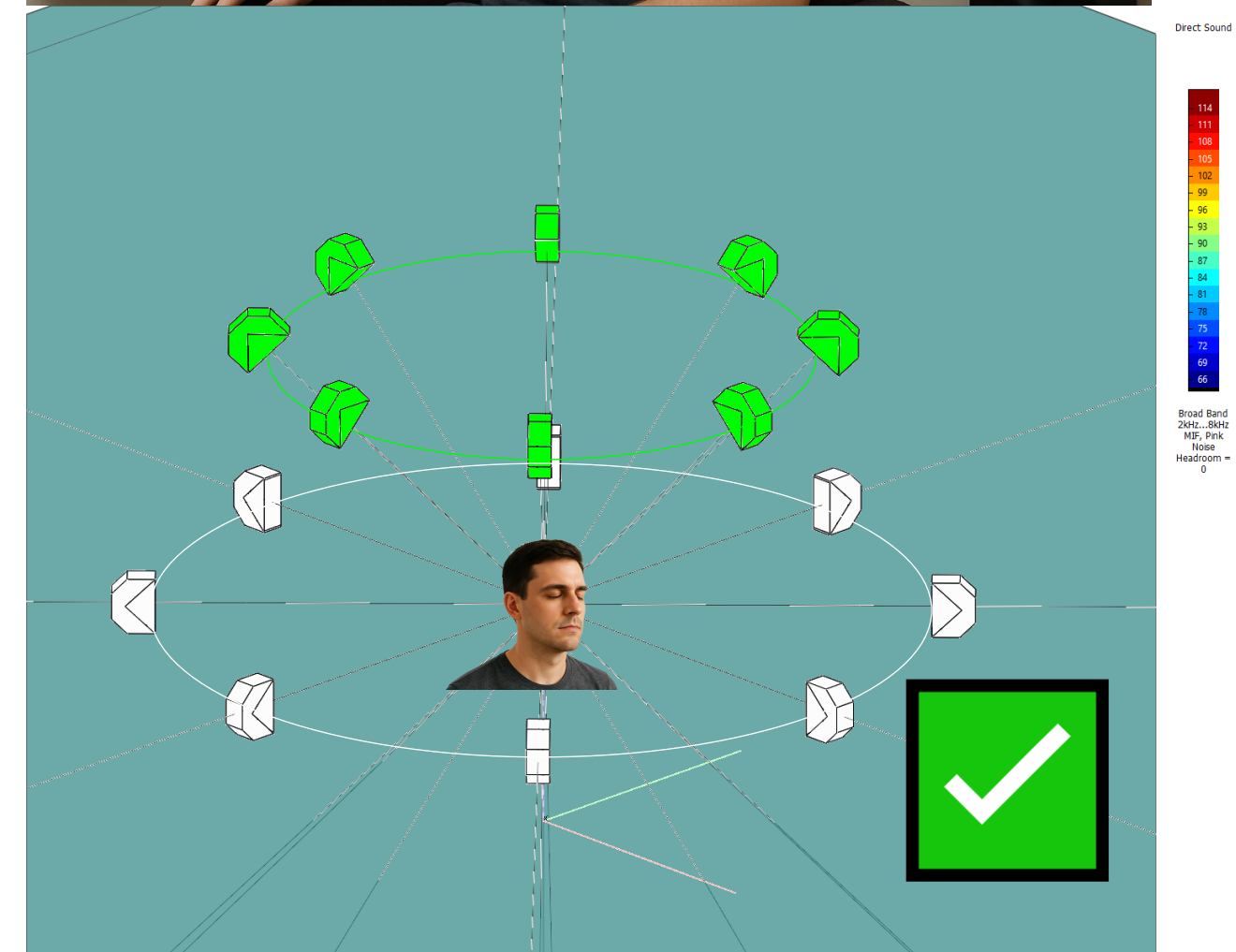

SDC 2025: Let's play some!

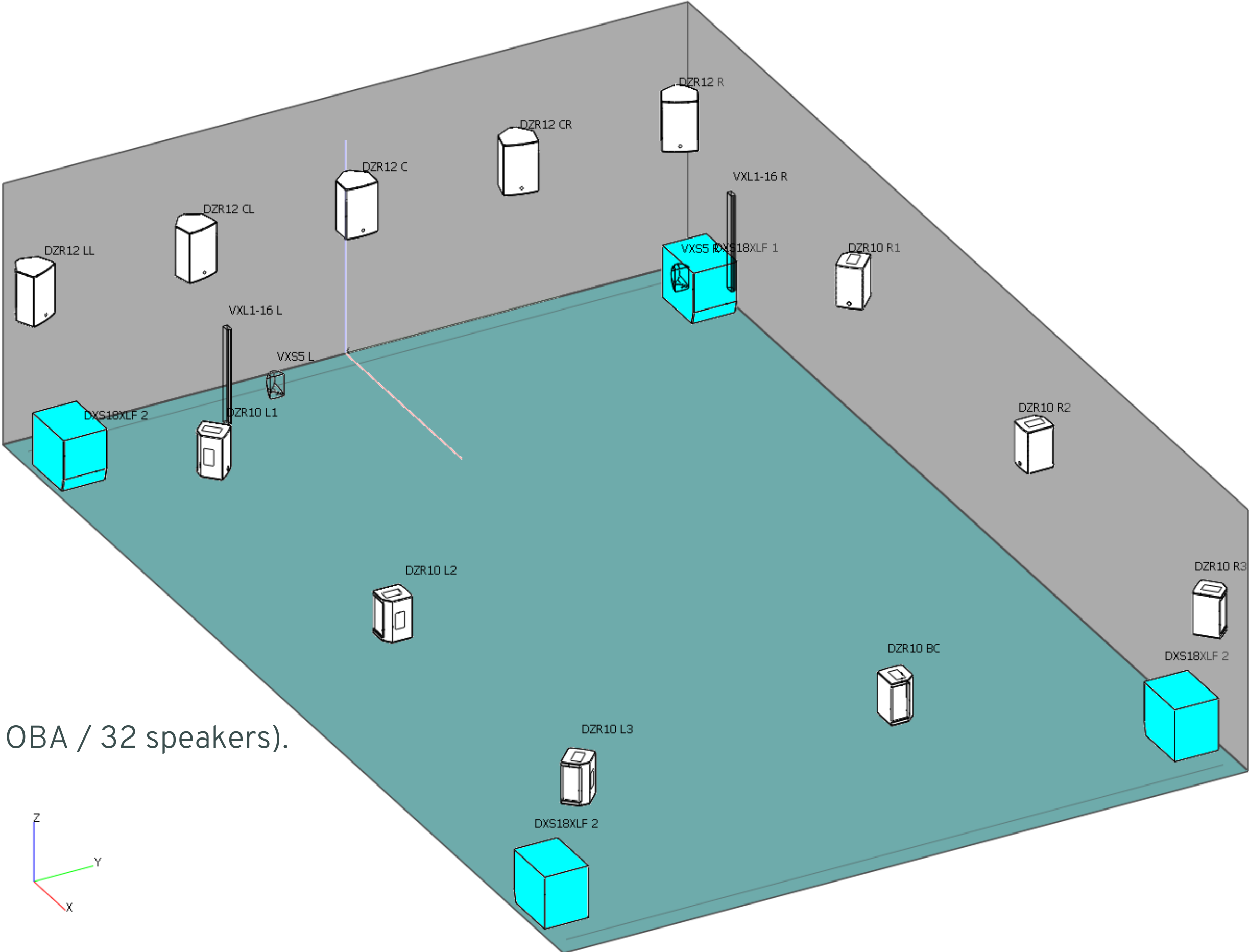
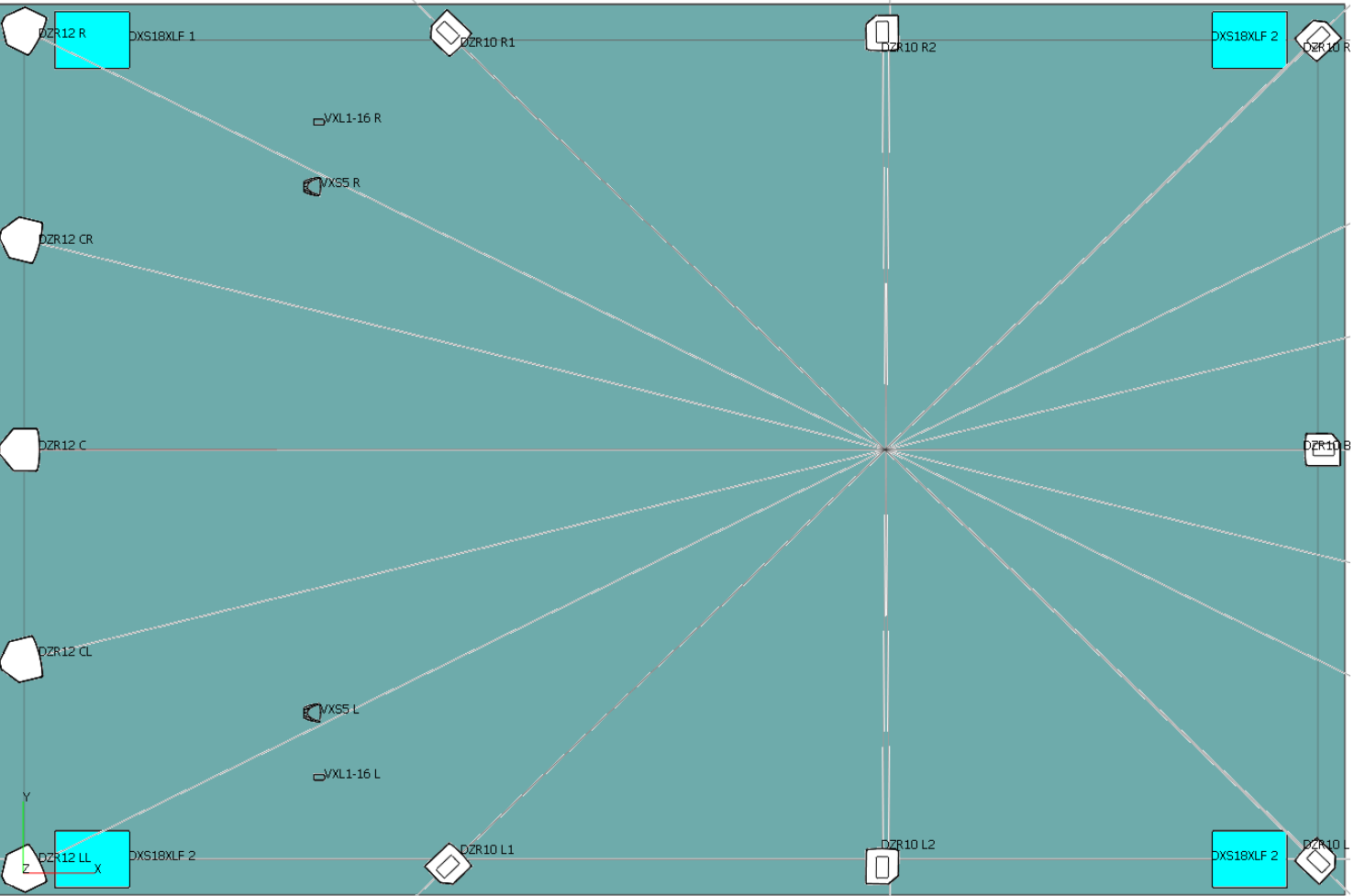

- Core: Yamaha DME7 with AFC Image license (64 OBA / 32 speakers).
- Front: 5x DZR12-D (direct imaging).
- Surround: 7x DZR10-D (13°-45° aperture).
- Subs: 4x DXS18XLF-D (bass support).

