

鉄筋コンクリート造（溶接）

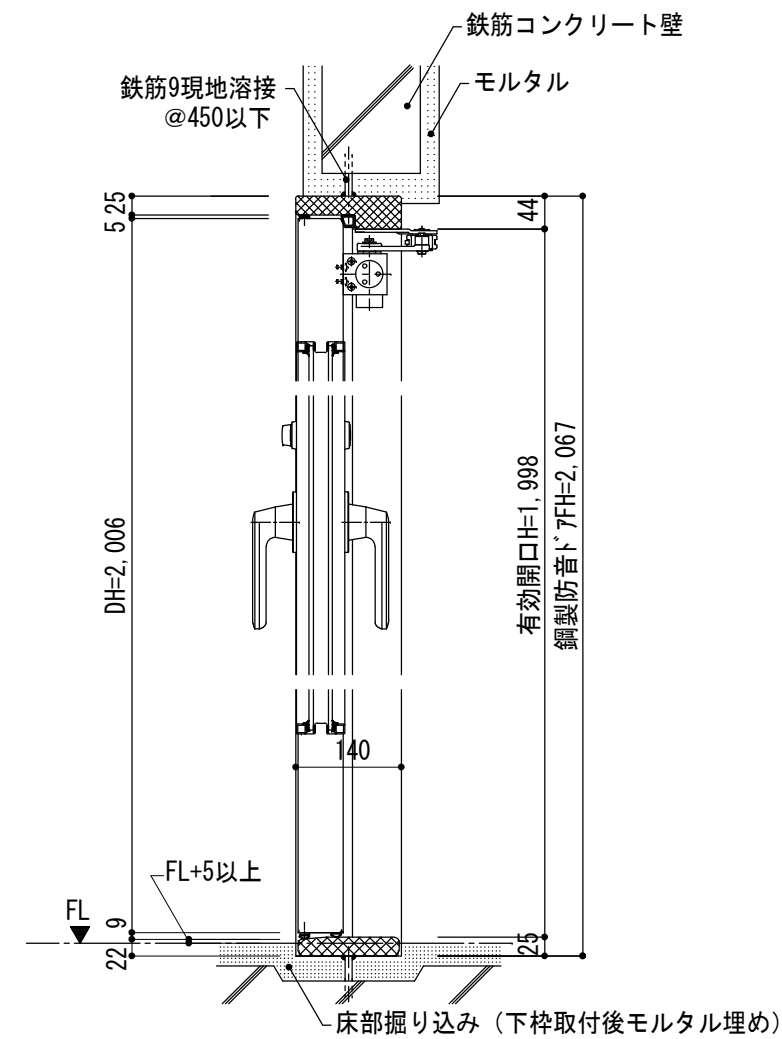

鉄骨造（溶接）

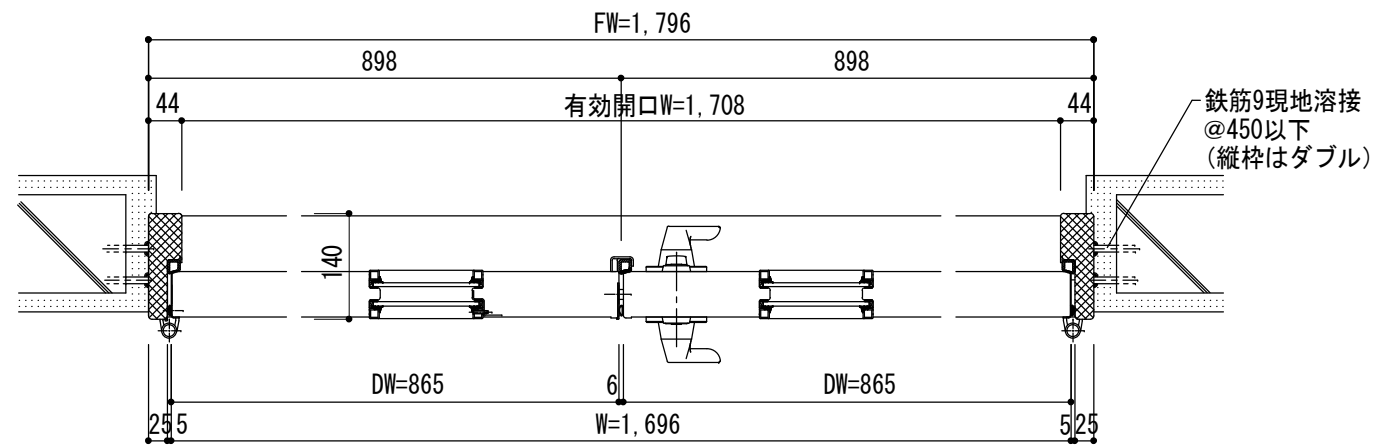